

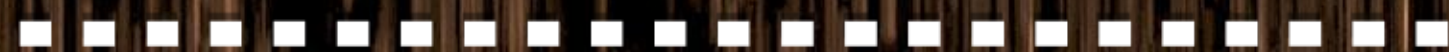

LUNAWOOD



PROVEN ENDURANCE

63°34`N 027°11`E

CLIP JUAN® TERRACE FASTENING SYSTEM

The time saving, patented and awarded innovation by Grad, the leading terrace building company in France.

- Saves even up to 70 % of the building time
- Quick and easy to install
- Invisible fastening system, no screws visible
- Very cost-effective compared to the total costs
- Works also for cladding



CLIP JUAN® TERRACE FASTENING SYSTEM THE INNOVATIVE STRIP



CLIP JUAN® - FACTS AND FIGURES

- Lunawood thermowood® is particularly suitable for the Clip JuAn® fastening system thanks to the fact that it is very stable and durable. Lunawood thermowood® also meets the needs for an environmentally friendly raw material.
- Nearly 885,000 lm of thermowood has been used for terraces with Clip JuAn® fastening system during the past 7 years by Grad.
- No complaints received!
- The system has been tested by an independent testing institute, the FCBA Bordeaux, which proved that Clip JuAn® is officially suitable for the requirements of the Norm DTU 51-4. The clip is protected by an European and Canadian patent (n °D63 B04 EUR)
- Clip JuAn® has been awarded with 3 gold medals.

WHY CLIP JUAN?

- The reasons behind this invention and how it works



INVENTION CREATED BY TWO PROFESSIONAL DECK BUILDERS

- The Clip JuAn® was created by two professional deck builders, Mr Jung and Mr Andres, in response to the specific problems they had encountered during their terrace building projects.

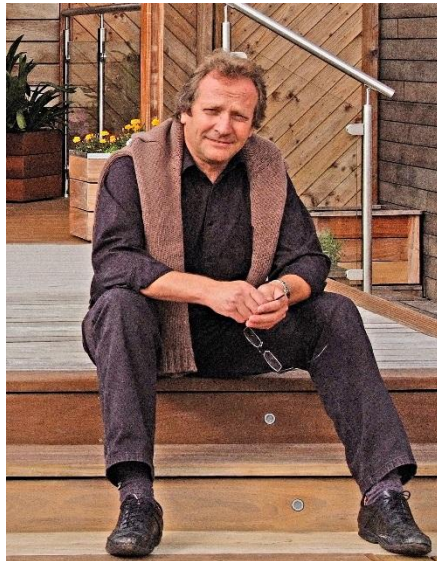

SCREWS

Problem

- The screws are often considered to be a risk of injury.
- The holes may damage the surface of the planks and have a negative affect to the overall look.

Solution

- Clip JuAn® is a totally invisible fastening system, no screws are visible.



NATURAL MATERIAL WOOD

Problem

- Wood expands and shrinks slightly by the influence of the air humidity.

Solution

- Thanks to the heat treatment, Lunawood thermowood® is much more stable than traditional wood.
- In addition, Clip JuAn® is flexible and supports the slight movement of the wood instead of preventing it.

THE DEFORMATION / TWISTING OF PLANKS

Problem

- The presence of the heart, the fact that the wood fibers are not running straight and the natural movement of the wood can affect negatively to the stability of the planks.

Solution

- The necessary grooves needed for Clip JuAn® reduce the nerves of the wood.



THE HOLDING RESISTANCE

Problem

- The gripping strength of the wood itself – also because of the wind – is in compliance with the values of the DTU (French standard for the construction of the decks) e.g. 100 kg for each fastening area

Solution

- The strip prevents the plank from removing from the groove.
- When wood is strong enough this value increases up to 160 kg.

THE VENTILATION

Problem

- The planks are ideal for the growth of fungi, algae and other micro-organisms in the points of joists.

Solution

- Since there is a free space of 5 mm between the plank and the joist, the system offers a very good ventilation and prevents the moisture and micro-organisms.

BUILDING TIME

Problem

- Marking, drilling and screwing are very time consuming and require often bad working position.

Solution

- Depending on the project Clip JuAn® can save up to 70 % of the building time.
- The installation is much more ergonomic compared to the traditional way of building a terrace – it is almost child's play!

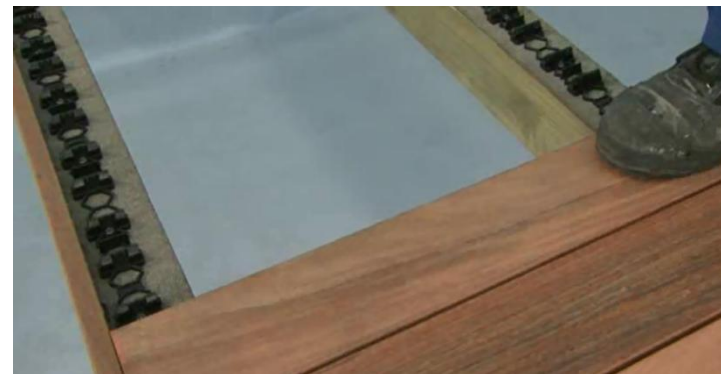

OVERALL LOOK OF THE TERRACE

Problem

- A beautiful, straight joint look is the main focus in a terrace.
- However, the planks are often different widths (even though only 1 mm) which complicates the work.
- The final look of the terrace is heavily depended on the skills and patience of the deck builder.

Solution

- Clip JuAn® ensures a totally uniform joint thanks to the clip.
- The perfect visual appearance is guaranteed.



INSTALLATION INSTRUCTIONS

- The key thing to remember is that the beginning of the clip has to coincide with the beginning of the joist.

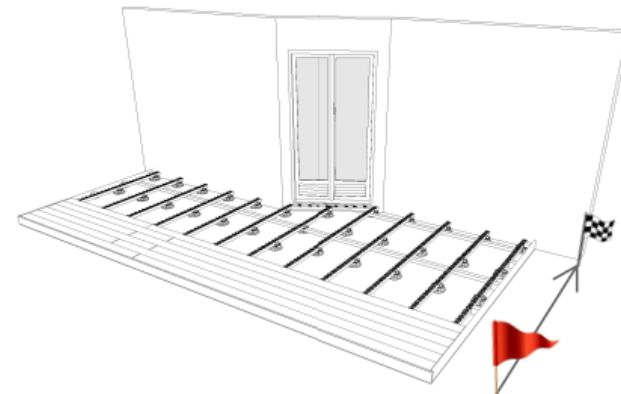
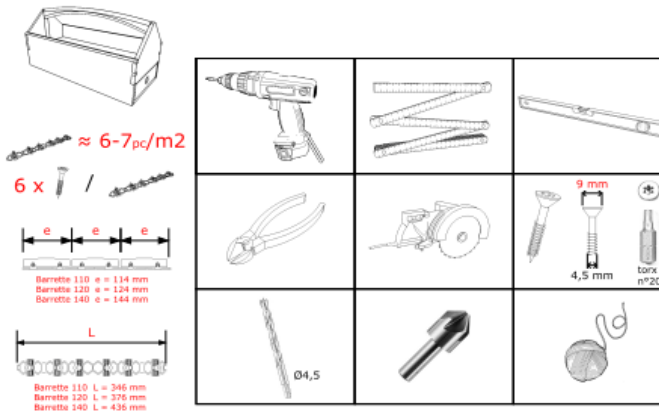

GUARANTEE OF LONGEVITY

- Clip JuAn® has guarantee for 25 years.
- It is made of polyoxymethylene which is a high-quality plastic that is used especially for the manufacturing of the ski shoe sole.
- Clip JuAn® works in a temperature range from -40° to $+70^{\circ}$.
- It is totally moisture resistant and therefore very durable.
- It is also protected from UV radiation.

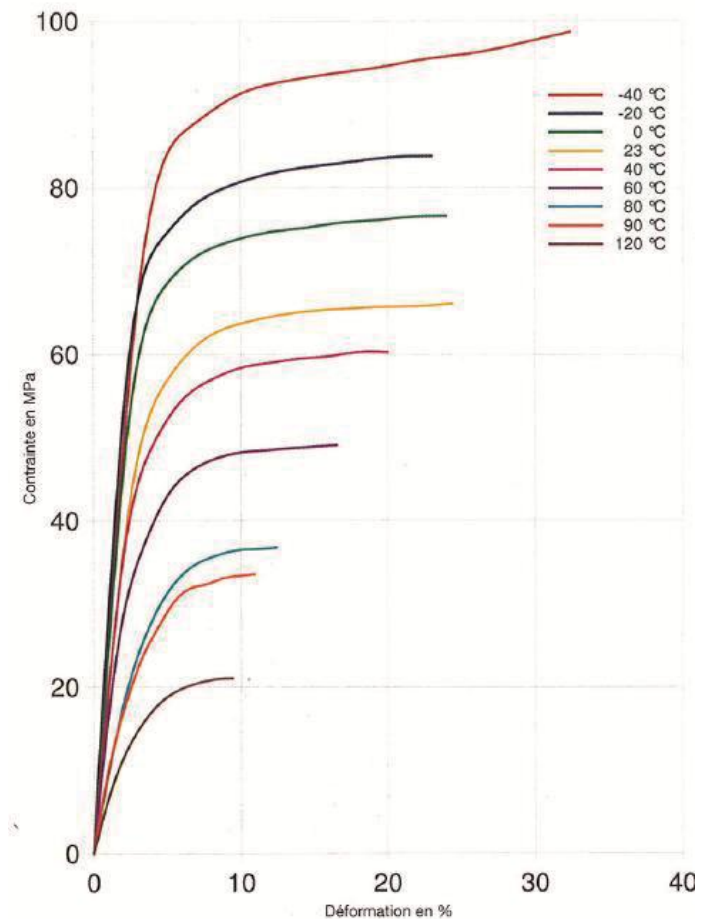

EASY TO INSTALL

- The strip with 6 access points is the easiest solution to install – there is no way to go wrong even for a DIY builder.



GROOVES

- Installing Clip JuAn® requires planks with a very special and complex grooves. The grooves can only be made with a grooving machine that is specially developed for this purpose.
- Lunawood's sub-supplier is specialized in pre-grooving the Lunawood thermowood® terrace products (in size 26x117) in a professional way.



COSTS OF USING CLIP JUAN

- The costs of using Clip JuAn® for the customer are approximately 8 euros per m² e.g. the price is very affordable.
- The corresponding price per m² when using traditional building methods varies between 5-12 euros.





LUNAWOOD

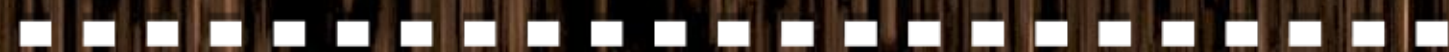

PROVEN ENDURANCE

63°34`N 027°11`E