



Version 2018-01

**RFPI® I-Joist DindasLVL® DindasRim®
Dindas Framing System**

Design Guide

Dindas Engineered Wood Products

DINDAS
australia

Contents

Typical floor framing and construction details	3
Recommended nail sizes and spacing	4
Rim board / I-Joist blocking max. factored vertical loads	4
Web stiffeners – size required	4
Residential floor span tables	5
Residential floor span tables – with ceramic tiles	6
Joist web stiffeners requirements	9
Floor framing details	10
I-Joist web holes	12
I-Joist cantilever reinforcement methods allowed	15
Typical roof framing and construction details	17
Roof framing details	18
Cantilevers for balconies (no wall load from above)	21
Construction precautions	23
Safety and construction precautions	24
Storage and handling guidelines	23

Dindas Engineered I-Joists Range

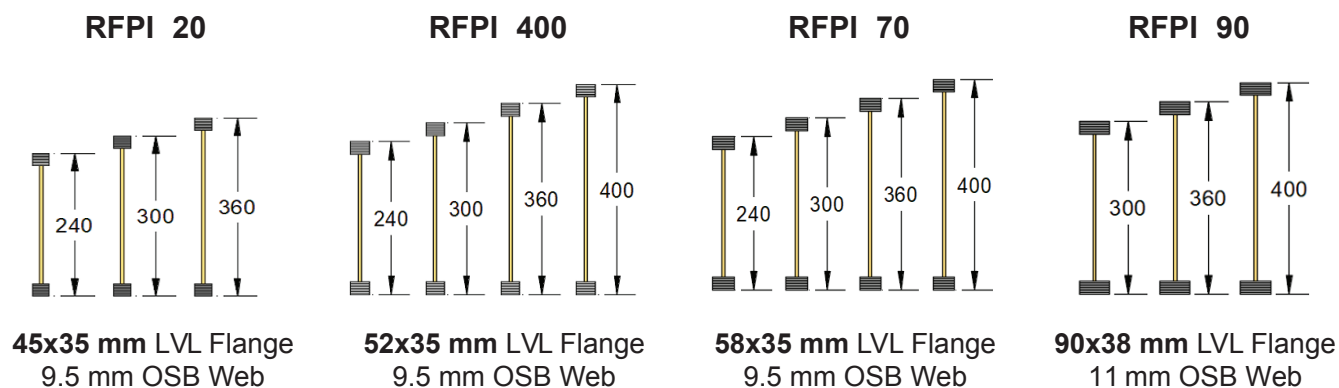

Typical floor framing and construction details

Figure 1

Some framing requirements such as erection bracing and blocking panels have been omitted for clarity. Refer to Dindas Australia Technical Bulletin series for further information on bracing and safe temporary load details.

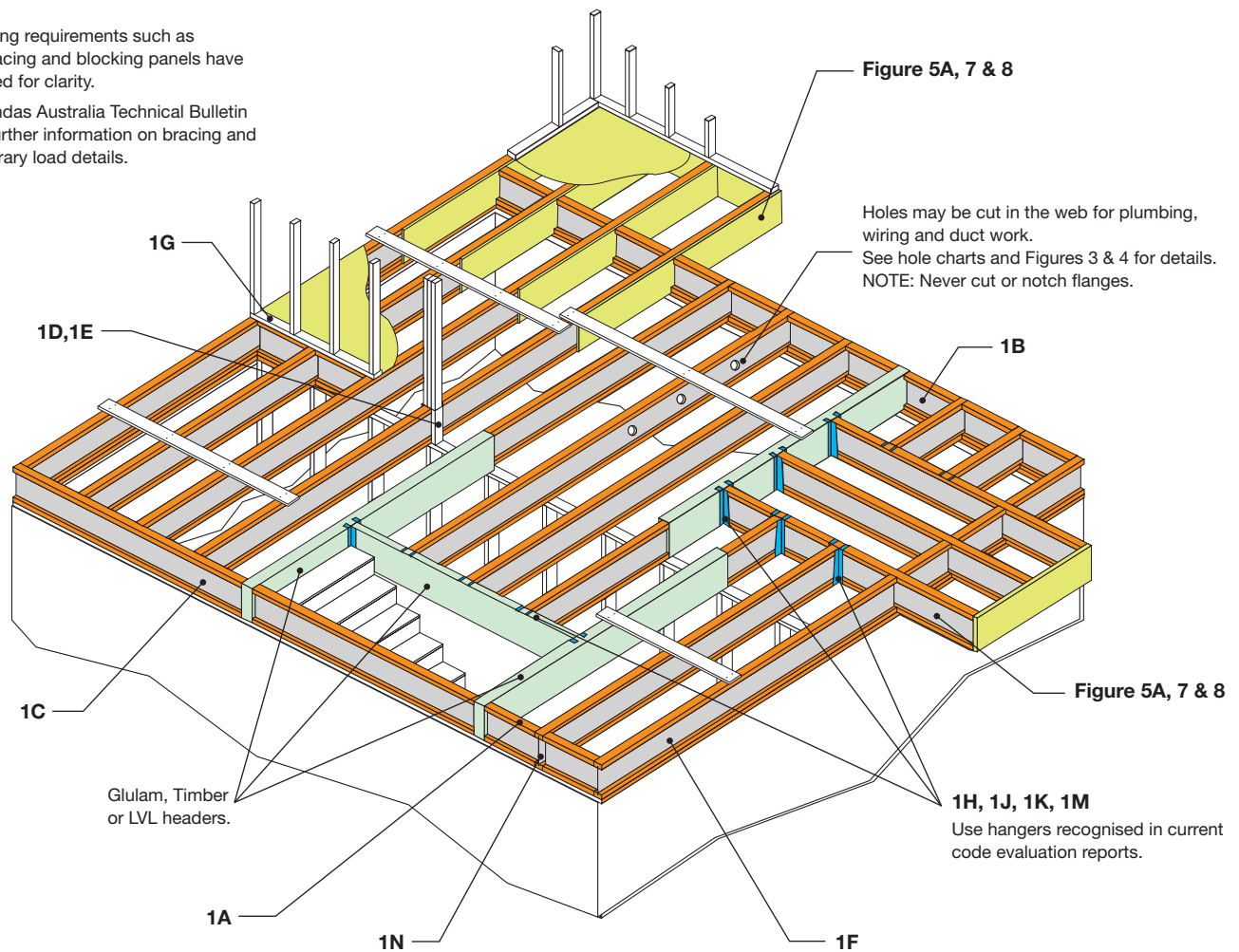

Notes:

- Do not allow workers on I-Joists until all hangers, Rim Joists, Rim Boards, RFP[®] Blocking Panels, and temporary strut lines are installed as specified below.
- Failure to install temporary bracing may result in sideways buckling or roll-over under light construction loads.
- Before laying out floor system components, verify that I-Joist flange widths match hanger widths.
- Build a braced end wall at the end of the bay, or permanently install the first 2.5 m of I-Joists and the first course of sheathing. As an alternate, temporary sheathing may be nailed to the first 1.25 m of I-Joists at the end of the bay.
- Install temporary strut lines at no more than 2.5 m on center as additional I-Joists are set. Nail the strut lines to the sheathing area, or brace end wall, to each I-Joist with two $\phi 3.15 \times 65$ mm nails.
- The end of the cantilevers must be temporarily secured by strut lines on both the top and bottom flanges.
- Remove the temporary strut lines only as required to install the permanent sheathing.
- Except for cutting to length, never cut, drill, or notch I-Joist flanges.
- I-Joists are produced without camber so either flange can be the top or bottom flange; however, orienting the floor I-Joists so the pre-scored knockouts are on the bottom may ease installation of electrical wiring or residential sprinkler systems.
- Install I-Joists so that top and bottom flanges are straight and remain within 2 mm of true vertical alignment.
- I-Joists must be anchored securely to supports before floor sheathing is attached, and supports for multiple-span joists must be level.
- Minimum bearing lengths: 35 mm for end bearings and 70 mm for intermediate bearings.
- When using hangers, seat I-Joists firmly in hanger bottoms to minimise settlement.
- Leave a 2 mm gap between the I-Joist end and a beam.
- Concentrated loads greater than those that can normally be expected in residential construction should only be applied to the top surface of the top flange. Never suspend unusual or heavy loads from the I-Joist's bottom flange. Whenever possible, suspend all concentrated loads from the top of the I-Joist. Or, attach the load to blocking that has been securely fastened to the I-Joist web.
- Never install I-Joists where they will be permanently exposed to weather or where they will remain in direct contact with concrete or masonry.
- Restrain ends of floor joists to prevent rollover. Use rimboard, rim joists or I-Joist blocking panels.
- For I-Joists installed over and beneath bearing walls, use full depth blocking panels, rimboard, or squash blocks to transfer gravity loads through the floor system to the wall or foundation below.
- Due to shrinkage, common framing timber set on edge cannot be used as blocking or rim boards.
- Provide permanent lateral support of the bottom flange of all I-Joists at interior supports of multiple-span joists. If square-edge panels are used, edges must be supported between I-Joists with 90x35 mm blocking. Glue panels to blocking to minimise squeaks. Blocking is not required under structural finish flooring, such as wood strip flooring, or if a separate underlayment layer is installed.
- See table on page 4 for recommended sheathing attachment with nails. If sheathing is to be attached with screws, the screw size should be equal to or only slightly larger than the recommended nail size. Space the screws the same as the required nail spacing. The unthreaded shank of the screw should extend beyond the thickness of the panel to assure that the panel is pulled securely against the I-Joist flange. Use screws intended for structural assembly of wood structures. It is recommended to use screws from a manufacturer that can provide an approved application specifications and design values. Drywall screws can be brittle and should not be used. Do not use nails larger or spaced closer than shown in the table from page 4. If more than one row of nails is required, rows must be offset by at least 12 mm and staggered. Nails on opposing flange edges must be offset one-half the minimum spacing.

Recommended nail sizes and spacing

Fastener size	Flange face nailing (mm)		Flange edge nailing (mm)		
	End distance	Nail spacing	End distance	Nailed to one flange edge	Nailed to both flange edges
$\phi \leq 3.25$ mm; 65 mm < length \leq 75 mm	75	50	75	75	150
3.25 mm < $\phi \leq$ 3.75 mm; 65 mm < length \leq 75 mm	75	75	75	75	150

Rim board / I-Joist blocking max. factored vertical loads

Rim Board / I-Joist Blocking	Thickness (mm)	Depth (mm)	Max. Factored Uniform Load, V (kN/m)	Max. Factored Concentrated Load, P (kN)
Plywood – F8	17	240	4.1	4.7
		300		4.5
		360		4.2
		400		4.1
	22	240	5.1	6.3
		300		6.1
		360		5.8
		400		5.7
	25	240	6.1	8.1
		300		7.9
		360		7.6
		400		7.5
Plywood – F11	17	240	5.1	5.3
		300		5.0
		360		4.7
		400		4.6
	22	240	6.3	7.0
		300		6.8
		360		6.5
		400		6.3
	25	240	7.6	9.0
		300		8.7
		360		8.5
		400		8.3
RFPI® Joists	flange width	\leq 400	20.0	-

Notes:

1. Tabulated factored capacities are for Category 1 or 2 applications and the load duration $k_1 \geq 0.8$.
2. For load durations $k_1 < 0.8$, adjust the tabulated values by 0.71.
3. For rim board subjected to a combination of uniform and concentrated vertical loads with the same load duration k_1 : - First, the total factored applied concentrated load shall not exceed the factored concentrated load capacity (P) based on a load bearing plate with a min. width of 70 mm. Second, the factored applied concentrated load

shall be calculated as an equivalent uniform load based on the factored applied concentrated load divided by the point load bearing plate width. The equivalent factored uniform load shall be applied to the existing factor uniform load to determine the total factored uniform load, which shall not exceed the factored uniform capacity (V). If the total factored uniform load exceeds the factored uniform capacity (V), appropriate squash blocks, double rim boards, or higher-grade rim boards shall be used to carry the concentrated vertical load.

4. The bearing resistance for the subfloor material and the sill plates shall be verified if the tabulated factored loads could be carried.
5. These maximum factored load capacities shall not be used in the design of bending member, such as joist, beam, or rafter.

Web stiffeners – size required

RFPI® Joist	Flange width (mm)	Web stiffeners size	
		Material	Thickness x min. width (mm x mm), each side of web
RFPI® 20	45	Plywood, Seasoned Timber, LVL	15 x 60
RFPI® 400	52		22 x 60
RFPI® 70	58		25 x 60
RFPI® 90	90		38 x 60

*see Figure 2 on page 9 for web stiffeners details

Residential floor span tables

Joist series	Joist depth x width (mm)	Floor span table: 1.5 Kpa live load; 40 kg/m ² dead load; Total permanent deflection: L/300 or 15 mm; live load deflection: L/360 or 9 mm									
		Max. single spans (mm)					Max. continuous spans (mm)				
		Joist spacing (mm)					Joist spacing (mm)				
		300	400	450	480	600	300	400	450	480	600
RFPI® 20	240x45	5100	4700*	4400*	4400*	4100*	5450	5050	4900	4850	4550
RFPI® 400	240x52	5300	4900*	4650*	4650*	4350*	5650	5250	5100	5000	4750
RFPI® 70	240x58	5700	5300*	5150*	5050	4750*	6150	5700	5500	5400	5100
RFPI® 20	300x45	5800	5400	5250*	5150	4850*	6250	5800	5600	5550	5200
RFPI® 400	300x52	6050	5600	5450*	5350	5050*	6500	6000	5850	5750	5400
RFPI® 70	300x58	6550	6050	5850	5750	5450*	7000	6500	6300	6200	5850
RFPI® 90	300x90	7200	6650	6450	6350	5950	7700	7150	6950	6800	6400
RFPI® 20	360x45	6450	5950	5800	5700	5350	6900	6400	6200	6100	5450
RFPI® 400	360x52	6650	6200	6000	5900	5550	7150	6650	6450	6300	5950
RFPI® 70	360x58	7200	6700	6450	6350	6000	7700	7150	6950	6850	6450
RFPI® 90	360x90	7900	7300	7100	7000	6550	8500	7850	7600	7500	7050
RFPI® 400	400x52	7200	6700	6500	6350	6000	7700	7150	6950	6850	6250
RFPI® 70	400x58	7800	7200	7000	6900	6500	8350	7750	7500	7400	6950
RFPI® 90	400x90	8550	7900	7650	7550	7100	9150	8500	8250	8100	7600

* Warning: 1.0kN dynamic load deflection is less than 2.0 mm, but exceeds 1.5 mm.

Joist series	Joist depth x width (mm)	Floor span table: 1.5 Kpa live load; 40 kg/m ² dead load; Total permanent deflection: L/300 or 11 mm; live load deflection: L/360 or 9 mm									
		Max. single spans (mm)					Max. continuous spans (mm)				
		Joist spacing (mm)					Joist spacing (mm)				
		300	400	450	480	600	300	400	450	480	600
RFPI® 20	240x45	4850	4550*	4400*	4350*	4100*	5200	4850	4750	4650	4400
RFPI® 400	240x52	5050	4700*	4550*	4500*	4250*	5400	5050	4900	4850	4550
RFPI® 70	240x58	5450	5050	4950*	4850	4600*	5800	5450	5300	5200	4950
RFPI® 20	300x45	5550	5200	5050*	4950	4700*	5950	5550	5400	5300	5050
RFPI® 400	300x52	5750	5350	5200	5150	4850*	6150	5750	5600	5500	5200
RFPI® 70	300x58	6200	5800	5600	5550	5250	6650	6200	6050	5950	5600
RFPI® 90	300x90	6700	6300	6100	6050	5700	7200	6750	6550	6450	6150
RFPI® 20	360x45	6100	5700	5550	5450	5150	6550	6100	5950	5850	5450
RFPI® 400	360x52	6300	5900	5750	5650	5350	6750	6350	6150	6050	5750
RFPI® 70	360x58	6800	6350	6200	6100	5750	7300	6800	6650	6550	6200
RFPI® 90	360x90	7350	6900	6700	6600	6250	7900	7400	7200	7100	6750
RFPI® 400	400x52	6800	6350	6200	6100	5750	7300	6850	6650	6550	6200
RFPI® 70	400x58	7300	6850	6650	6550	6200	7850	7350	7150	7050	6650
RFPI® 90	400x90	7950	7450	7250	7150	6750	8500	8000	7750	7650	7250

* Warning: 1.0kN dynamic load deflection is less than 2.0 mm, but exceeds 1.5 mm.

Residential floor span notes:

- Spans shown are in accordance with NCC 2016, AS 1170.0, AS 1170.1, AS 1720.1, AS 1684.1 & ASTM D 5055
- Tables are based on the uniform standard loads of **1.5 kPa uniform live load, 1.8 kN concentrated live load, and 40 kg/m² dead load.**
- Maximum spans listed are the design spans (center to center of the bearing supports).
- Minimum end bearing length is 35 mm.**
- Minimum interior bearing length is 70 mm.**
- Max. permanent deflection is limited to the lesser of L/300 and the absolute deflection (mm) as indicated in the floor span tables ($I_p = 2$).
- Max. live load deflection is limited to the lesser of L/360 or 9 mm.
- Max. dynamic load (1kN) deflection is limited to 2 mm.
- Short term factor = 1.0 for serviceability for the uniform live load.
- g41 and g42 factors were used where applicable.
- Lateral support must be provided at the bearings to prevent lateral displacement or rotation.
- Continuous restraint to the top edge is assumed to be provided by the glued and nailed subfloor.
- Bottom edge restraint shall be provided by the ceiling (suspended ceiling does not provide restraint) or by battens (600 mm max. spacing).
- When using continuous spans over an intermediate bearing, the shortest span shall not be less than 75% of the longest adjacent span.
- If the shortest span (including cantilevers) is shorter than 75% of the longest span, each span shall be considered single.
- The end of the shorter span should be anchored to resist the uplift.
- Tabulated values shown are valid for **Category 1**, Class 1 applications.
- Tabulated values shown assume a glued and nailed subfloor:**
 - The subfloor panel shall be structurally rated (Plywood – F8 minimum grade).
 - The subfloor panel thickness shall be min. 15 mm for o.c. spacings <= 400 mm, and min. 18 mm for o.c. spacings > 400 mm.
 - Fasten the subfloor panel to the top flange with $\phi 3.25 \times 65$ mm nails spaced at 300 mm along the intermediate supports, and 150 mm along the exterior panel edges.
 - Use construction adhesive. Apply adhesive (about 6 mm – diameter bead) to top flange in a continuous line. Complete all nailing on each panel before the glue sets. Check with the adhesive manufacturer's recommendations for allowable time.

Residential floor span tables (Continued)

Joist series	Joist depth x width (mm)	Floor span table: 1.5 Kpa live load; 40 kg/m ² dead load; Total permanent deflection: l/300 or 9 mm; live load deflection: l/360 or 9 mm									
		Max. single spans (mm)					Max. continuous spans (mm)				
		Joist spacing (mm)					Joist spacing (mm)				
		300	400	450	480	600	300	400	450	480	600
RFP1® 20	240x45	4600	4300*	4200*	4100	3900*	4950	4650	4500	4400	4200
RFP1® 400	240x52	4800	4450	4350*	4250	4050*	5150	4800	4650	4600	4350
RFP1® 70	240x58	5150	4800	4650	4600	4350	5500	5150	5000	4950	4650
RFP1® 20	300x45	5250	4900	4800	4700	4450	5650	5300	5150	5050	4800
RFP1® 400	300x52	5450	5100	4950	4850	4600	5850	5450	5300	5250	4950
RFP1® 70	300x58	5850	5500	5300	5250	4950	6300	5900	5700	5650	5350
RFP1® 90	300x90	6350	5950	5800	5700	5400	6850	6400	6250	6150	5800
RFP1® 20	360x45	5800	5400	5250	5200	4900	6200	5800	5650	5550	5250
RFP1® 400	360x52	6000	5600	5450	5350	5050	6400	6000	5850	5750	5450
RFP1® 70	360x58	6450	6000	5850	5750	5450	6900	6450	6300	6200	5850
RFP1® 90	360x90	7000	6550	6350	6250	5950	7500	7000	6850	6750	6350
RFP1® 400	400x52	6450	6050	5850	5800	5450	6950	6500	6300	6200	5850
RFP1® 70	400x58	6950	6500	6300	6200	5900	7450	7000	6800	6700	6300
RFP1® 90	400x90	7500	7050	6850	6750	6400	8050	7550	7350	7250	6850

* Warning: 1.0kN dynamic load deflection is less than 2.0 mm, but exceeds 1.5 mm.

Joist series	Joist depth x width (mm)	Floor span table: 1.5 Kpa live load; 40 kg/m ² dead load; Total permanent deflection: l/300 or 7.5 mm; live load deflection: l/360 or 9 mm									
		Max. single spans (mm)					Max. continuous spans (mm)				
		Joist spacing (mm)					Joist spacing (mm)				
		300	400	450	480	600	300	400	450	480	600
RFP1® 20	240x45	4400	4100	4000*	3950	3700*	4750	4400	4300	4200	4000
RFP1® 400	240x52	4550	4250	4150	4050	3850	4900	4550	4450	4350	4150
RFP1® 70	240x58	4900	4600	4450	4400	4150	5250	4900	4800	4700	4450
RFP1® 20	300x45	5000	4700	4550	4500	4250	5400	5050	4900	4800	4550
RFP1® 400	300x52	5200	4850	4700	4650	4400	5550	5200	5050	5000	4700
RFP1® 70	300x58	5600	5200	5050	5000	4700	6000	5600	5450	5350	5050
RFP1® 90	300x90	6050	5700	5500	5450	5150	6500	6100	5950	5850	5550
RFP1® 20	360x45	5550	5150	5000	4950	4650	5950	5550	5400	5300	5000
RFP1® 400	360x52	5700	5350	5200	5100	4850	6100	5700	5550	5500	5200
RFP1® 70	360x58	6150	5750	5600	5500	5200	6600	6150	6000	5900	5600
RFP1® 90	360x90	6650	6250	6050	5950	5650	7150	6700	6500	6400	6050
RFP1® 400	400x52	6150	5750	5600	5500	5200	6600	6200	6000	5900	5600
RFP1® 70	400x58	6600	6200	6000	5900	5600	7100	6650	6450	6350	6000
RFP1® 90	400x90	7150	6700	6500	6400	6100	7700	7200	7000	6900	6350

* Warning: 1.0kN dynamic load deflection is less than 2.0 mm, but exceeds 1.5 mm.

Joist series	Joist depth x width (mm)	Floor span table: 1.5 Kpa live load; 40 kg/m ² dead load; Total permanent deflection: l/300 or 6 mm; live load deflection: l/360 or 9 mm									
		Max. single spans (mm)					Max. continuous spans (mm)				
		Joist spacing (mm)					Joist spacing (mm)				
		300	400	450	480	600	300	400	450	480	600
RFP1® 20	240x45	4150	3850	3750	3700	3500	4450	4150	4050	4000	3750
RFP1® 400	240x52	4300	4000	3900	3850	3600	4600	4300	4200	4100	3900
RFP1® 70	240x58	4600	4300	4200	4100	3900	4950	4650	4500	4450	4200
RFP1® 20	300x45	4750	4400	4300	4200	4000	5100	4750	4600	4550	4300
RFP1® 400	300x52	4900	4550	4450	4350	4150	5250	4900	4750	4700	4450
RFP1® 70	300x58	5250	4900	4800	4700	4450	5650	5300	5150	5050	4800
RFP1® 90	300x90	5700	5350	5200	5100	4850	6150	5750	5600	5500	5200
RFP1® 20	360x45	5200	4850	4750	4650	4400	5600	5200	5100	5000	4750
RFP1® 400	360x52	5400	5050	4900	4800	4550	5750	5400	5250	5150	4900
RFP1® 70	360x58	5800	5400	5250	5150	4900	6200	5800	5650	5550	5250
RFP1® 90	360x90	6250	5850	5700	5600	5300	6750	6300	6100	6050	5700
RFP1® 400	400x52	5800	5400	5250	5200	4900	6250	5800	5650	5550	5250
RFP1® 70	400x58	6250	5850	5650	5600	5250	6700	6250	6100	6000	5650
RFP1® 90	400x90	6750	6300	6150	6050	5700	7250	6800	6600	6500	6150

Note: Tabulated spans shown above shall be read in conjunction with the residential floor span notes from page 5.

Residential floor span tables – with ceramic tiles

Joist series	Joist depth x width (mm)	Floor span table: 2.0 Kpa live load; 62 kg/m ² dead load; Total permanent deflection: L/360 or 15 mm; live load deflection: L/360 or 9 mm									
		Max. single spans (mm)					Max. continuous spans (mm)				
		Joist spacing (mm)					Joist spacing (mm)				
		300	400	450	480	600	300	400	450	480	600
RFPI® 20	240x45	4300	3900	3750	3650	3400	4750	4300	4150	4050	3500
RFPI® 400	240x52	4500	4100	3950	3850	3550	4950	4500	4350	4250	3900
RFPI® 70	240x58	5000	4550	4350	4250	3950	5450	5000	4800	4700	4350
RFPI® 20	300x45	5150	4650	4500	4400	4050	5600	5150	4950	4750	3800
RFPI® 400	300x52	5400	4900	4700	4600	4250	5800	5400	5200	5050	4350
RFPI® 70	300x58	5800	5400	5200	5100	4700	6250	5800	5650	5550	4850
RFPI® 90	300x90	6350	5900	5750	5650	5300	6800	6350	6150	6050	5750
RFPI® 20	360x45	5750	5350	5100	5000	4650	6150	5650	5000	4700	3800
RFPI® 400	360x52	5950	5550	5350	5250	4850	6350	5950	5750	5450	4350
RFPI® 70	360x58	6400	5950	5800	5700	5350	6850	6400	6200	6050	4850
RFPI® 90	360x90	6950	6500	6300	6200	5850	7500	6950	6750	6650	6150
RFPI® 400	400x52	6400	5950	5800	5700	5400	6850	6400	6200	6050	4850
RFPI® 70	400x58	6900	6450	6250	6150	5800	7400	6900	6700	6550	4900
RFPI® 90	400x90	7500	7000	6800	6700	6300	8050	7500	7300	7200	6150

Joist series	Joist depth x width (mm)	Floor span table: 2.0 Kpa live load; 62 kg/m ² dead load; Total permanent deflection: L/360 or 9 mm; live load deflection: L/360 or 9 mm									
		Max. single spans (mm)					Max. continuous spans (mm)				
		Joist spacing (mm)					Joist spacing (mm)				
		300	400	450	480	600	300	400	450	480	600
RFPI® 20	240x45	4000	3700	3600	3550	3350	4300	4000	3850	3800	3500
RFPI® 400	240x52	4150	3850	3750	3650	3450	4450	4150	4000	3950	3700
RFPI® 70	240x58	4450	4150	4000	3950	3700	4800	4450	4300	4250	4000
RFPI® 20	300x45	4550	4250	4100	4050	3800	4900	4550	4400	4350	3800
RFPI® 400	300x52	4700	4400	4250	4200	3950	5050	4700	4550	4500	4250
RFPI® 70	300x58	5050	4700	4600	4500	4250	5450	5050	4900	4850	4550
RFPI® 90	300x90	5550	5150	5000	4900	4650	5950	5550	5350	5300	5000
RFPI® 20	360x45	5000	4650	4550	4450	4200	5400	5000	4850	4700	3800
RFPI® 400	360x52	5200	4850	4700	4600	4350	5550	5200	5050	4950	4350
RFPI® 70	360x58	5600	5200	5050	4950	4700	6000	5600	5400	5350	4850
RFPI® 90	360x90	6050	5650	5500	5400	5100	6500	6050	5900	5800	5450
RFPI® 400	400x52	5600	5200	5050	4950	4700	6000	5600	5450	5350	4350
RFPI® 70	400x58	6000	5600	5450	5350	5050	6450	6000	5850	5750	4900
RFPI® 90	400x90	6550	6100	5900	5800	5500	7050	6550	6350	6250	5900

Residential Floor Span (with Ceramic Tiles) Notes:

- Spans shown are in accordance with NCC 2016, AS 1170.0, AS 1170.1, AS 1720.1, AS 1684.1 & ASTM D 5055
- Tables are based on the uniform standard loads of **2.0 kPa uniform live load, 1.8 kN concentrated live load, and 62 kg/m² dead load.**
- Maximum spans listed are the design spans (center to center of the bearing supports).
- Minimum end bearing length is 35 mm.**
- Minimum interior bearing length is 70 mm.**
- Max. permanent deflection is limited to the lesser of L/360 and the absolute deflection (mm) as indicated in the floor span tables ($i_p = 2$).
- Max. live load deflection is limited to the lesser of L/360 or 9 mm.
- Max. dynamic load (1kN) deflection is limited to 2 mm.
- Short term factor = 1.0 for serviceability for the uniform live load.
- g41 and g42 factors were used where applicable.
- Lateral support must be provided at the bearings to prevent lateral displacement or rotation.
- Continuous restraint to the top edge is assumed to be provided by the glued and nailed subfloor.
- Bottom edge restraint shall be provided by the ceiling (suspended ceiling does not provide restraint) or by battens (600 mm max. spacing).
- When using continuous spans over an intermediate bearing, the shortest span shall not be less than 75% of the longest adjacent span.
- If the shortest span (including cantilevers) is shorter than 75% of the longest span, each span shall be considered single.
- The end of the shorter span should be anchored to resist the uplift.
- Tabulated values shown are valid for **Category 1 or 2**, Class 1 applications.
- Tabulated values shown assume a glued and nailed subfloor:**
 - The subfloor panel shall be structurally rated (Plywood – F8 minimum grade).
 - The subfloor panel thickness shall be min. 19 mm. Underlayment panel: 18 mm minimum installed with corrosion-resistant fasteners.**
 - Fasten the subfloor panel to the top flange with $\phi 3.25 \times 65$ mm nails spaced at 300 mm along the intermediate supports, and 150 mm along the exterior panel edges.
 - Use construction adhesive. Apply adhesive (about 6 mm – diameter bead) to top flange in a continuous line. Complete all nailing on each panel before the glue sets. Check with the adhesive manufacturer's recommendations for allowable time.

Residential floor span tables – with ceramic tiles (Continued)

Joist series	Joist depth x width (mm)	Floor span table: 2.0 Kpa live load; 62 kg/m ² dead load; Total permanent deflection: L/360 or 6 mm; live load deflection: L/360 or 9 mm									
		Max. single spans (mm)					Max. continuous spans (mm)				
		Joist spacing (mm)					Joist spacing (mm)				
		300	400	450	480	600	300	400	450	480	600
RFPI® 20	240x45	3600	3350	3250	3150	3000	3850	3600	3450	3400	3200
RFPI® 400	240x52	3700	3450	3350	3300	3100	4000	3700	3600	3550	3350
RFPI® 70	240x58	4000	3700	3600	3550	3350	4300	4000	3850	3800	3600
RFPI® 20	300x45	4100	3800	3700	3600	3400	4400	4100	3950	3900	3650
RFPI® 400	300x52	4250	3950	3800	3750	3550	4550	4250	4100	4050	3800
RFPI® 70	300x58	4550	4250	4100	4050	3800	4900	4550	4400	4350	4100
RFPI® 90	300x90	4950	4600	4450	4400	4150	5300	4950	4800	4700	4450
RFPI® 20	360x45	4500	4200	4050	4000	3750	4850	4500	4350	4300	3800
RFPI® 400	360x52	4650	4350	4200	4150	3900	5000	4650	4500	4450	4200
RFPI® 70	360x58	5000	4650	4500	4450	4200	5400	5000	4850	4750	4500
RFPI® 90	360x90	5450	5050	4900	4800	4550	5850	5450	5250	5200	4900
RFPI® 400	400x52	5000	4650	4550	4450	4200	5400	5000	4850	4800	4350
RFPI® 70	400x58	5400	5000	4850	4800	4500	5800	5400	5250	5150	4850
RFPI® 90	400x90	5850	5450	5300	5200	4900	6300	5850	5700	5600	5250

Note: Tabulated spans shown above shall be read in conjunction with the floor span notes from page 7.

Recommendations for floors with ceramic tiles:

1. The building codes require a maximum deflection of L/360 for the floor joists and for the floor panel, where L is the center-to-center distance between supports for the floor joists, and the on center spacing between joists for the panel.
2. The 19 mm plywood may not meet the L/360 deflection when installed over 600 mm joists, and two layers with the strong axis perpendicular to the joists may have to be used.
3. The plywood layers should be screwed and glued before the membrane is installed.
4. The underlayment should have a minimum thickness of 18 mm and installed with the strong axis perpendicular to joists.
5. Limit the joists spans to 4.0 m.

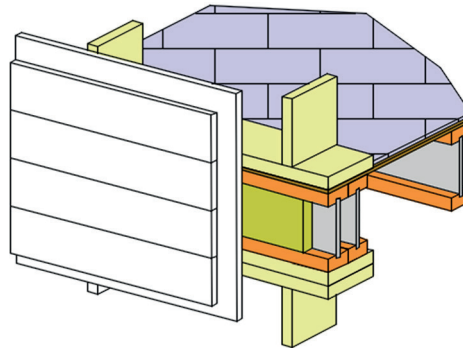

Joist web stiffeners requirements

Figure 2

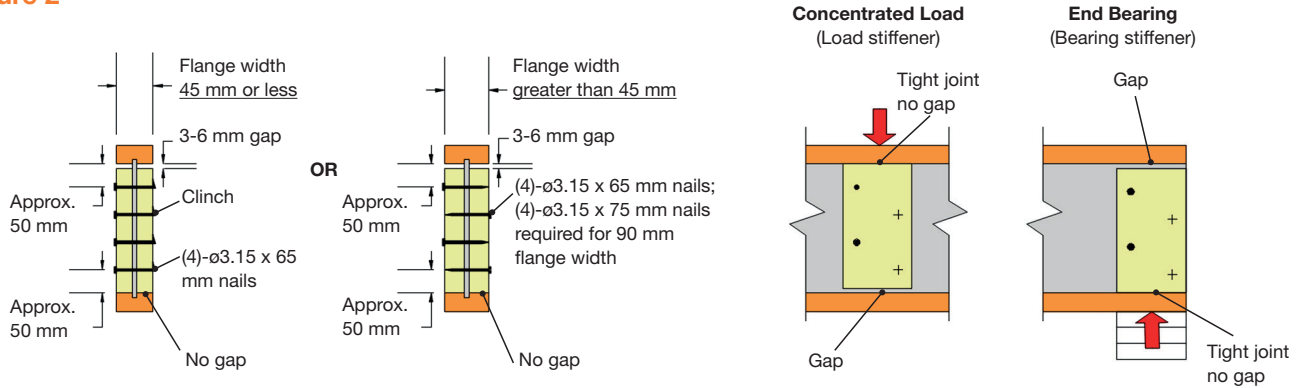

Notes:

1. Web stiffeners are required:

- When sides of the hangers do not laterally brace the top flange of each I-Joist.
- When I-Joists are designed to support concentrated factored loads greater than 9.5 kN applied to the I-Joist's top flange between supports. In these applications only, the gap between the web stiffener and the flange shall be at the bottom flange.

- For Birdsmouth cuts on roof I-Joists.

2. When used at end bearings, install web stiffeners tight against the bottom flange of the I-Joist. Leave a minimum 3-6 mm gap between the top of the stiffener and the bottom of the top flange (see Figure 2).
3. Web stiffeners may be cut in the field as required.

Floor framing details

Diagram 1A Blocking at Exterior Wall

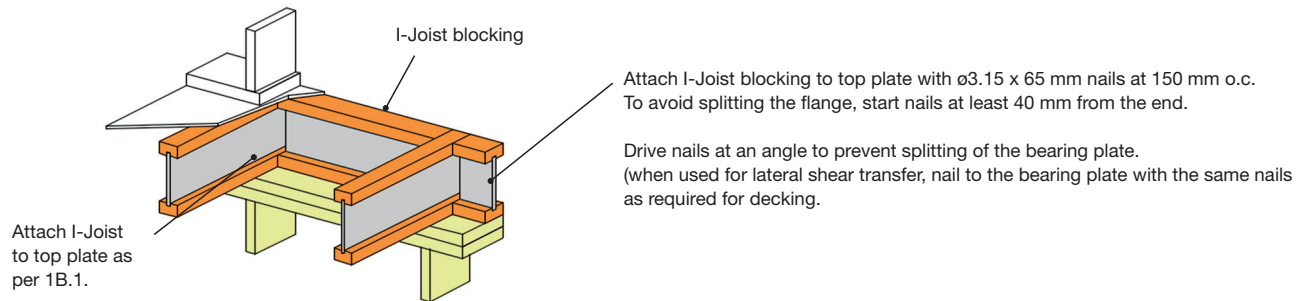

Diagram 1B.1 Rim Board at Exterior Wall (perp. joists)

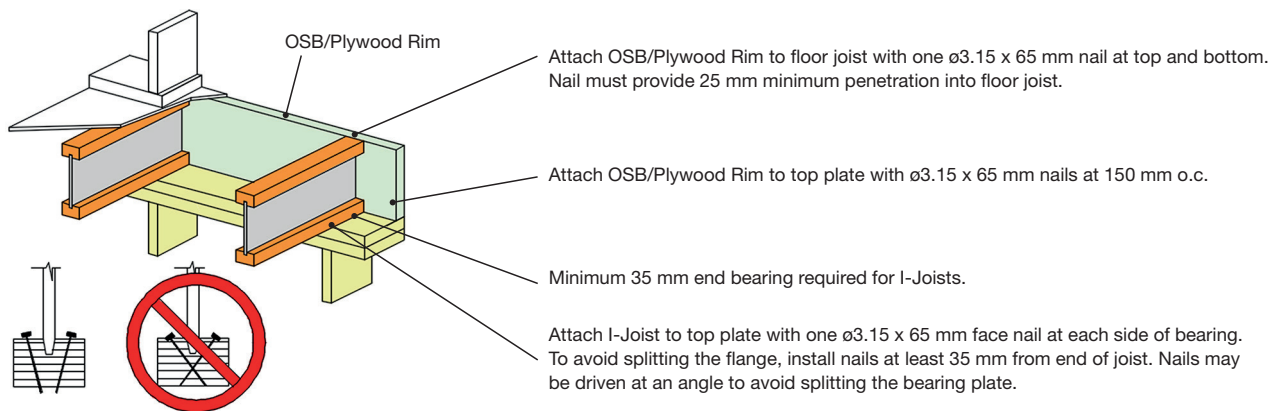

Diagram 1B.2 Exterior End Wall Support (perp. blocking)

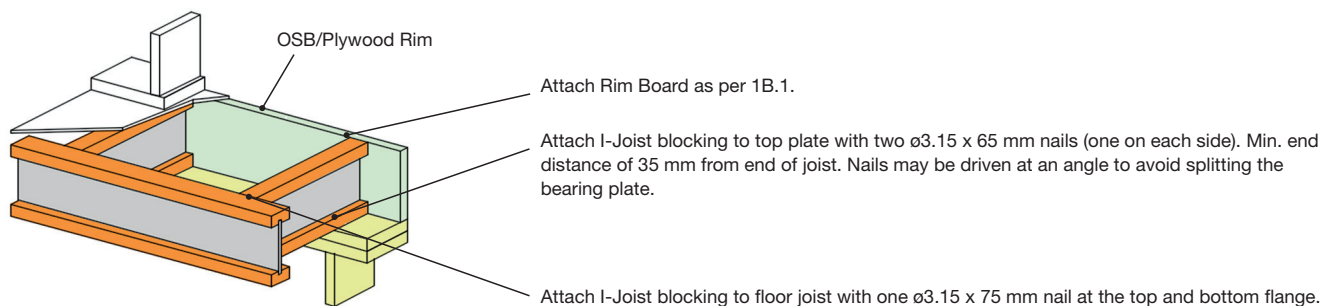

Diagram 1B.3 Exterior End Wall Support (parallel joists)

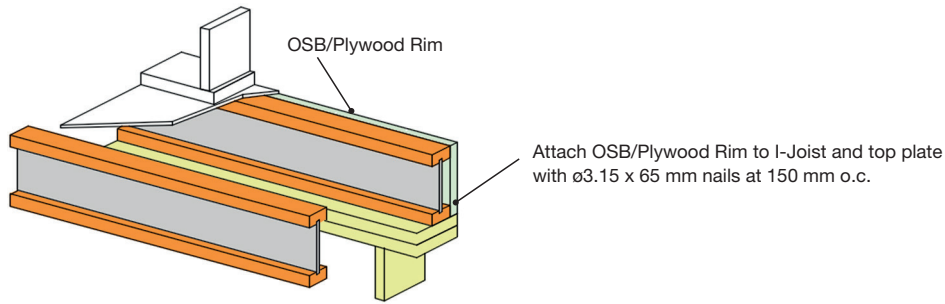

Diagram 1C Rim I-Joist at Exterior Wall

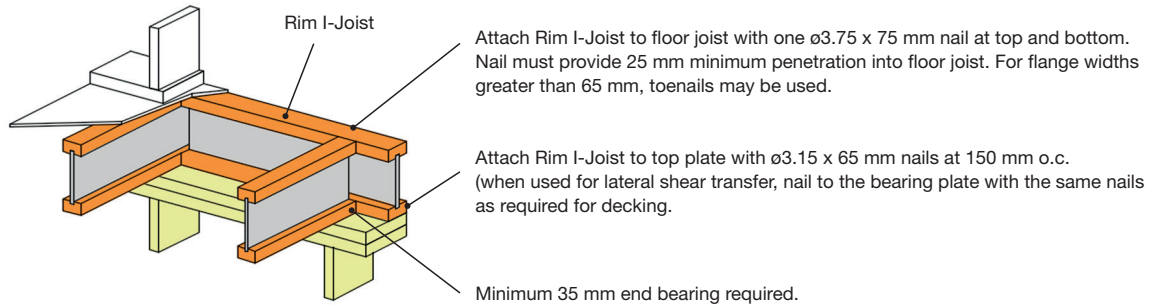
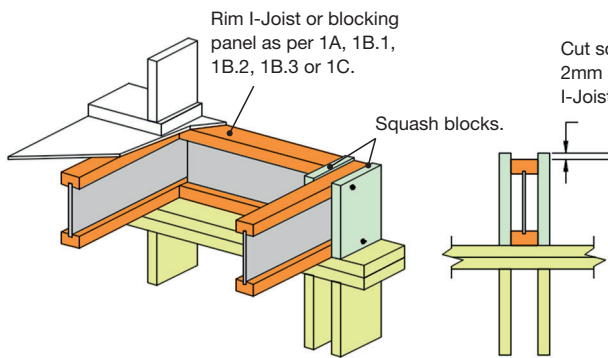

Diagram 1D Squash Blocks



Squash Blocks	I-Joist Depth	Squash Blocks Cross Section (mm x mm)	Max. Factored Vertical Load per Pair of Squash Blocks (kN)	
			MGP10 wall plate bearing analysis included	
			No	Yes
MGP10 (min. grade)	max. 400 mm	35 x 90	64	30
		45 x 90	82	39
		45 x 140	127	61

Provide lateral bracing as per 1A, 1B.1, 1B.2, 1B.3 or 1C. Squash blocks are assumed to be in full bearing on the plate below. Fasten squash blocks to the top flange and to the top plate with one $\phi 3.15 \times 65$ mm nail.

Diagram 1E Concentrated Loads at Studs or Posts

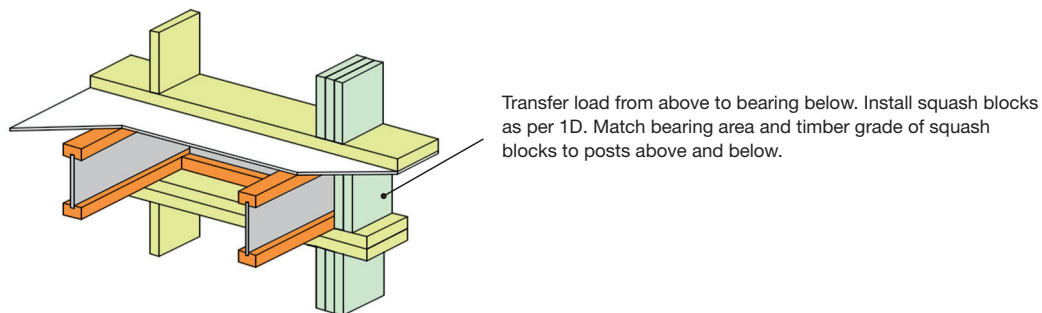

Diagram 1F Double I-Joist Rim

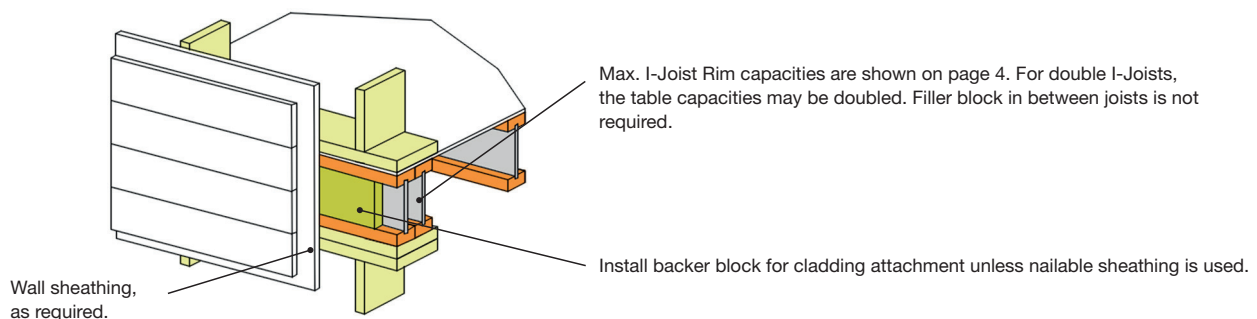
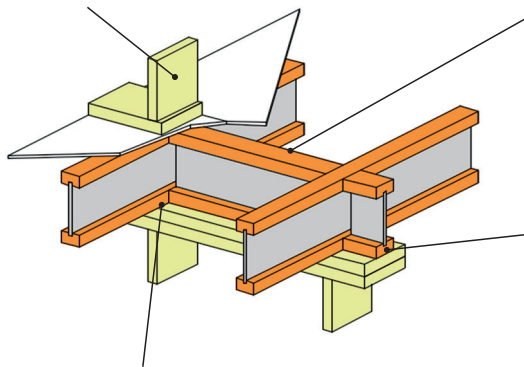

Diagram 1G Blocking at Interior Support

Load bearing wall from above shall align vertically with the wall below. Other conditions, such as offset walls, are not covered by this detail.



Attach I-Joist to top plate as per 1B.1.

Blocking required over all interior supports under load-bearing walls or when floor joists are not continuous over supports.

When two joists meet over a wall, provide 35 mm minimum end bearing for each joist and install blocking to laterally support both joists.

Max. I-Joist Blocking factored capacity = 20 kN/m.
Rim Board blocking capacities are shown on page 4.

Attach I-Joist blocking to top plate with $\phi 3.15 \times 65$ mm nails at 150 mm o.c. (when used for shear transfer, nail to the bearing plate with the same nails as required for decking).

Diagram 1H I-Joist to Trimmer Connection

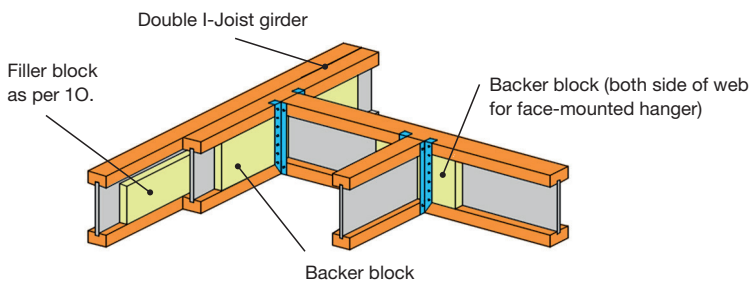

I-Joist depth (mm)	Plywood (F8) backer block height (mm)	# of $\phi 3.75 \times 75$ mm nails (clinched) to fasten the backer block	Max. factored load (kN)
240	160	16	7.0
300	220	20	8.5
360	270	20	8.5
400	320	20	8.5

I-Joist flange width (mm)	Plywood (F8) backer block thickness (mm)
45	17
52	22
58	25
90	28

Notes:

- Backer block required for face-mount hangers (both sides of I-Joist) & when top mount hanger factored load exceeds 1.0 kN.
- See charts above for backer block thickness and height.
- Backer block min. length = 375 mm.** Backer block must be long enough to permit required nailing without splitting.
- Install backer block tight to the top flange.
- Attach backer block with the number of nails and nail type as per chart above. Min. nail distances are as follows:
 - Min. nail end distance = 75 mm
 - Min. nail edge distance = 20 mm
 - Min. distance between nails in a row = 75 mm
 - Min. distance between rows of nails = 38 mm
- For hanger capacity see hanger manufacturer recommendations.
- Verify I-Joist capacity to support "header joist" load, in addition to all other loads.
- If a double I-Joist is required to support "girder joist" load, refer to Figure 5 for filler block and double I-Joist connection guidelines.
- Before installing a backer block to a double I-Joist, drive 4 additional $\phi 3.75 \times 75$ mm nails from both sides of double I-Joist through the web and filler block at backer block location. Clinch nails.
- Web stiffeners shall be installed, unless the top/face mounted hanger sides laterally support the top flange.
- Minimum grade for backer material shall be Plywood – F8.

Diagram 1J I-Joist To Beam Connection

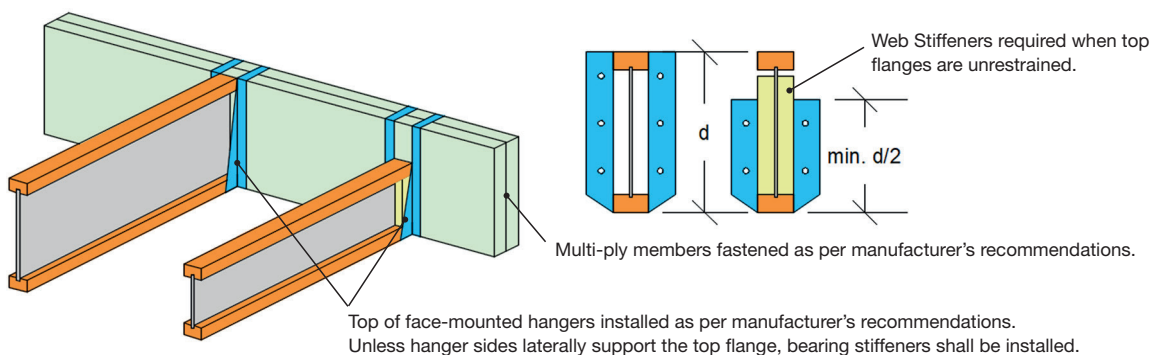

Multi-ply members fastened as per manufacturer's recommendations.

Top of face-mounted hangers installed as per manufacturer's recommendations. Unless hanger sides laterally support the top flange, bearing stiffeners shall be installed.

Diagram 1K I-Joist To Steel Beam Connection

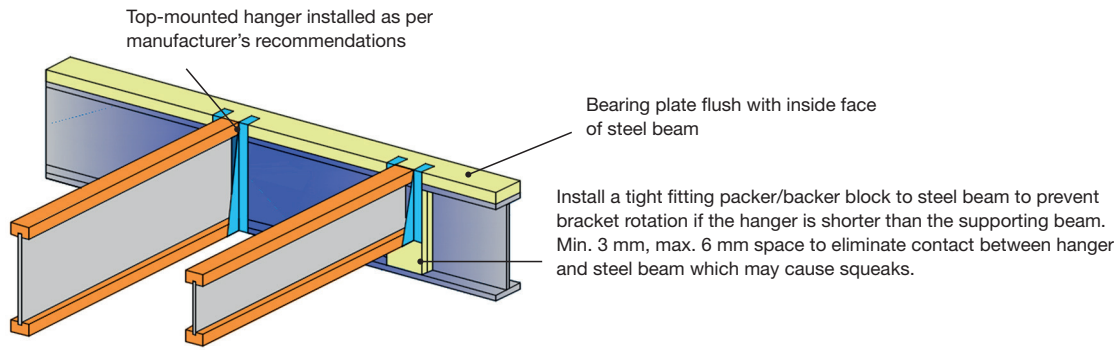

Diagram 1M Stair Stringer

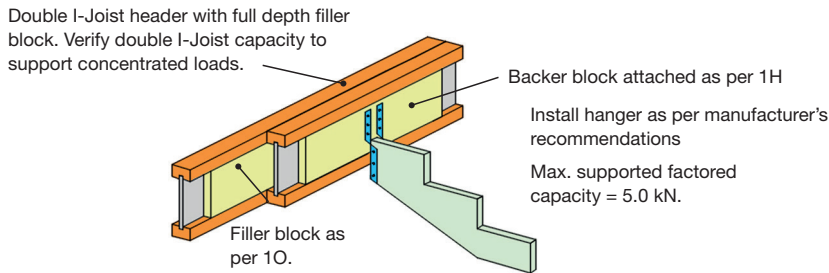

Diagram 1N Bevel Cut

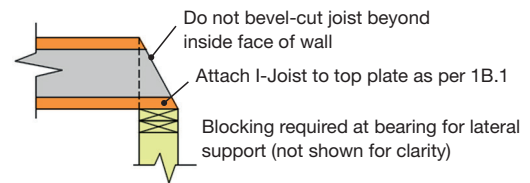
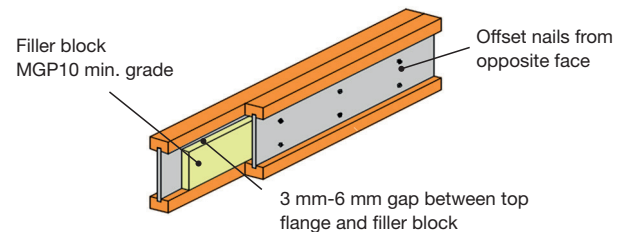

Diagram 10 Double I-Joists Detail

- Double I-Joists may be required for frame openings, support concentrated loads, support partitions parallel to floor joists, or support any other loads which would exceed the capacity of a single I-joist. Install double I-joists when noted in the building drawings.
- Filler blocks do not function as web stiffeners. If web stiffeners are required, it is recommended to install continuous filler block and install web stiffener below filler block prior to attaching I-Joist reinforcement. Leave 6 mm gap between the top of filler block and bottom of top I-Joist flange. Web stiffeners must be tight between top of bottom flange and bottom of filler block.
- Support back of I-Joist web during nailing to prevent damage to web/flange connection.
- Leave a 3mm gap between top of filler block and bottom of top I-joist flange.
- For side-loaded conditions or cantilever reinforcement, filler block is required between joists for full length of double member.
- Nail joists together with two rows of 3.15 x 65 mm nails at 150 mm o.c. spacing (staggered) on each side of the double I-Joist. Total of 8 nails per 3 m required.
- Filler block thickness may be achieved by using multiple layers of structural wood panels.
- The maximum factored load that may be applied to one side of the double joists using this detail is 7.15 kN/m.

Joists series	Flange width (mm)	Joist depth (mm)	Net filler block size (mm x mm)
RFPI® 20	45	240	35 x 150
		300	35 x 200
		360	35 x 250
RFPI® 400	52	240	45 x 150
		300	45 x 200
		360	45 x 250
		400	45 x 300
RFPI® 70	58	240	50 x 150
		300	50 x 200
		360	50 x 250
RFPI® 90	90	400	50 x 300
		300	75 x 200
		360	75 x 250
		400	75 x 300



I-Joist web holes

Web holes may be cut in the I-Joist web to accommodate electrical wiring, plumbing lines and other mechanical systems based on the following rules:

1. Holes must be sized and located in compliance with the holes charts. Holes may be located vertically anywhere in the web provided a minimum distance of 3 mm of web remaining between the edge of the hole and the flanges.
2. Where more than one hole is necessary, the distance between the adjacent holes edges must be a minimum of twice the diameter of the largest circular hole or twice the size of the largest square/rectangular hole.
3. Knockout holes (40 mm circular predrilled holes spaced approximately 400 mm on center spacing) are not considered holes and they can be utilised anywhere they occur. Knockouts can be ignored for the purposes of calculating the minimum distances between the holes and the maximum number of holes allowed for each span.
4. A 40-mm circular hole is permitted anywhere in cantilever spans. A 40-mm circular hole can be placed anywhere in the web provided that it meets the requirements of rule 2.
5. A group of circular holes at approximately the same location shall be permitted if they meet the requirements for a single circular hole circumscribed around them.
6. All holes must be cut in a workman-like manner.
7. No more than three holes (any shapes) are permitted per span (excluding knockouts).

How to use the hole chart:

- Read across the top of Hole Chart to the desired hole size (or the next bigger size).
- Follow this column down to the row that represents the I-Joist depth and designation.
- This number indicates the minimum distance from the face of the support to the centerline of the hole.

Example:

Need a 140 mm round hole in a 240 mm RFPI® 400 Joist with a design span of 4.0 m:
From the Hole Chart for the round and square web holes:
For a 150 mm round hole, the minimum distance is 1.1 m.
Therefore the minimum distance for the 140 mm round hole is 1.1 m.

Circular and square holes

Figure 3

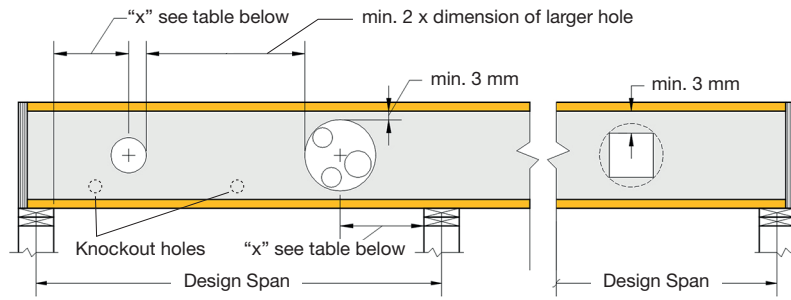

Joist series	Design span (m)	Min. distance from face of nearest support to center of hole, "x" (m)									
		Circular holes: max. diameter (mm)									
		75	100	125	150	175	200	225	250	275	300
Square holes: max. size (mm)											
		50	75	90	110	130	150	160	180	200	225
RFPI® 20 240x45	3.0	0.2	0.3	0.3	0.4						
	4.0	0.2	0.3	0.6	1.0						
	5.0	0.3	0.7	1.2	1.8						
	5.5	0.6	1.1	1.6	2.1						
RFPI® 20 300x45	3.0	0.2	0.3	0.3	0.3	0.3	0.3				
	4.0	0.2	0.3	0.3	0.3	0.5	1				
	5.0	0.2	0.3	0.3	0.8	1.2	1.7				
	6.0	0.2	0.5	1	1.4	1.9	2.5				
RFPI® 20 360x45	4.0	0.2	0.3	0.3	0.3	0.3	0.3	0.6	1		
	5.0	0.2	0.3	0.3	0.3	0.4	0.8	1.3	1.7		
	6.0	0.2	0.3	0.3	0.6	1.1	1.5	2.0	2.5		
	6.5	0.2	0.3	0.5	1.0	1.4	1.8	2.3	2.8		
RFPI® 400 240x52	3.0	0.2	0.3	0.3	0.4						
	4.0	0.2	0.3	0.6	1.1						
	5.0	0.3	0.7	1.2	1.8						
	5.5	0.6	1.1	1.6	2.1						
RFPI® 400 300x52	3.0	0.2	0.3	0.3	0.3	0.3	0.3				
	4.0	0.2	0.3	0.3	0.3	0.5	0.9				
	5.0	0.2	0.3	0.3	0.7	1.1	1.6				
	6.0	0.2	0.4	0.9	1.3	1.8	2.4				
RFPI® 400 360x52	4.0	0.2	0.3	0.3	0.3	0.3	0.3	0.5	0.9		
	5.0	0.2	0.3	0.3	0.3	0.3	0.7	1.1	1.6		
	6.0	0.2	0.3	0.3	0.4	0.9	1.3	1.8	2.4		
	6.5	0.2	0.3	0.3	0.8	1.2	1.7	2.2	2.7		
RFPI® 400 400x52	4.0	0.2	0.3	0.3	0.3	0.3	0.3	0.3	0.3	0.4	0.9
	5.0	0.2	0.3	0.3	0.3	0.3	0.3	0.3	0.6	1.1	1.6
	6.0	0.2	0.3	0.3	0.3	0.3	0.4	0.9	1.3	1.8	2.3
	6.5	0.2	0.3	0.3	0.3	0.3	0.7	1.2	1.7	2.2	2.7
RFPI® 70 240x58	3.0	0.2	0.3	0.3	0.3						
	4.0	0.2	0.3	0.4	0.9						
	5.0	0.2	0.5	1	1.6						
	6.0	0.7	1.2	1.7	2.3						
RFPI® 70 300x58	4.0	0.2	0.3	0.3	0.3	0.4	0.8				
	5.0	0.2	0.3	0.3	0.6	1.0	1.6				
	6.0	0.2	0.3	0.7	1.2	1.7	2.3				
	6.5	0.2	0.6	1.1	1.6	2.1	2.7				
RFPI® 70 360x58	4.0	0.2	0.3	0.3	0.3	0.3	0.3	0.4	0.8		
	5.0	0.2	0.3	0.3	0.3	0.3	0.6	1.0	1.5		
	6.0	0.2	0.3	0.3	0.3	0.8	1.2	1.7	2.3		
	6.5	0.2	0.3	0.3	0.6	1.1	1.6	2.1	2.6		
RFPI® 70 400x58	4.0	0.2	0.3	0.3	0.3	0.3	0.3	0.3	0.3	0.4	0.9
	5.0	0.2	0.3	0.3	0.3	0.3	0.3	0.3	0.7	1.1	1.6
	6.0	0.2	0.3	0.3	0.3	0.3	0.4	0.9	1.3	1.8	2.3
	6.5	0.2	0.3	0.3	0.3	0.3	0.7	1.2	1.7	2.2	2.7
RFPI® 90 300x90	4.0	0.2	0.3	0.3	0.3	0.3	0.3				
	5.0	0.2	0.3	0.3	0.3	0.3	0.9				
	6.0	0.2	0.3	0.3	0.3	1.0	1.6				
	6.5	0.2	0.3	0.3	0.7	1.3	2				
RFPI® 90 360x90	4.0	0.2	0.3	0.3	0.3	0.3	0.3	0.3	0.4		
	5.0	0.2	0.3	0.3	0.3	0.3	0.3	0.5	1.1		
	6.0	0.2	0.3	0.3	0.3	0.3	0.6	1.2	1.8		
	6.5	0.2	0.3	0.3	0.3	0.4	0.9	1.5	2.1		
RFPI® 90 400x90	4.0	0.2	0.3	0.3	0.3	0.3	0.3	0.3	0.3	0.3	0.6
	5.0	0.2	0.3	0.3	0.3	0.3	0.3	0.3	0.3	0.7	1.3
	6.0	0.2	0.3	0.3	0.3	0.3	0.3	0.3	0.9	1.4	2
	6.5	0.2	0.3	0.3	0.3	0.3	0.3	0.7	1.2	1.7	2.3

Notes:

- Distances "x" in this table apply to single or continuous spans with a maximum oc. spacing of 600 mm and the loading conditions shown below.
- Distances "x" in this table are valid for the maximum design spans indicated in the table. The design spans shown shall be verified for the specific loading conditions before checking the hole location. For shorter design spans, the minimum hole distances from the next available (longer) design span shall be used.
- Hole location distance is measured from inside face of the nearest bearing support to center of hole.
- A minimum distance of 3 mm must be maintained between the top or bottom of the hole and the flange edge.
- Where more than one hole is necessary, the distance between adjacent hole edges shall equal or exceed twice the diameter of the largest circular hole or twice the size of the largest square hole or twice the length of the longest side of the rectangular hole. Each hole must be sized and located in compliance with the requirements of the table specific to the shape of the hole.
- For I-Joists with more than one span, use the longest span to determine the hole size and location in either span.
- A group of circular holes at approximately the same location shall be permitted if they meet the requirements for a single round hole circumscribed around them.
- Square holes are not permitted for cantilever spans.
- Square holes should be located at mid-height of the web.
- The sizes of square holes should not exceed 3/4 of the diameter of the maximum round hole permitted at that location.

Loading conditions:

- **Dead load:** self-weight + 62 kg/m²
- **Live load:** 2.0 kPa or 1.8 kN
- **Structural member:** Self-contained dwelling; Category 1
- **Dry use service conditions:** Equilibrium moisture content of the joist shall not exceed 18 %

Knockout holes

Knockouts are prescored holes for the contractor's convenience to install electrical or small plumbing lines. They are 40 mm in diameter, and are spaced approximately 400 mm on center along the length of the I-Joist. Where possible, it is preferable to use knockouts instead of field cutting holes. For floor applications, position the I-Joists so the knockouts are all on the bottom of the joist, making it easier to install electrical wiring or residential sprinkler systems.

For square holes, avoid over-cutting the corners, as this may cause stress concentration. Start the square hole by drilling a 25 mm-diameter hole in each of the four corners and then make the cuts between the holes to minimise damage to the web.

I-Joist cantilever reinforcement methods allowed

Figure 5A

Method 1 – Sheathing reinforcement one side

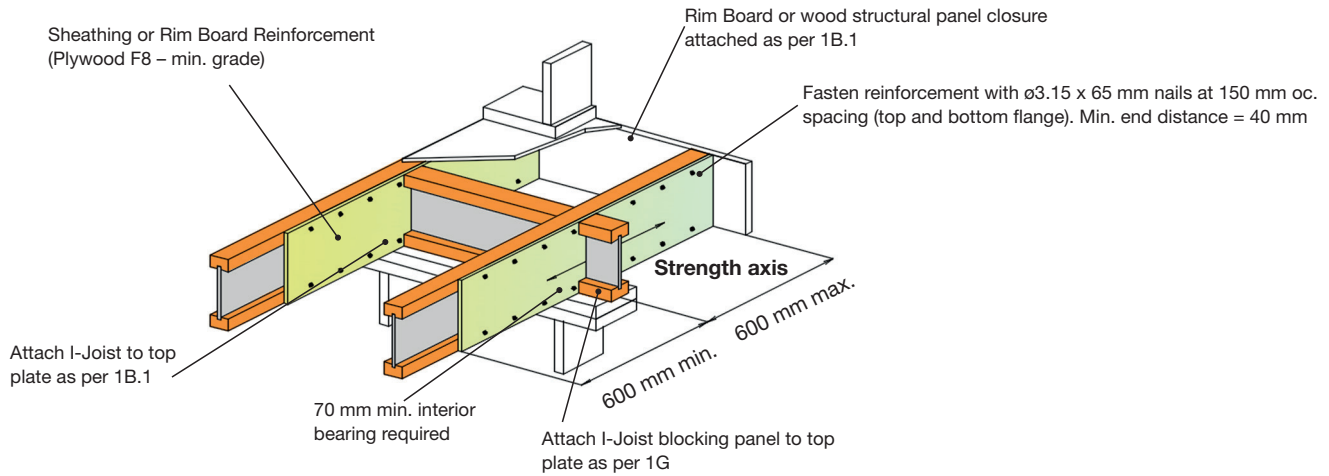

Method 2 – Sheathing reinforcement two sides

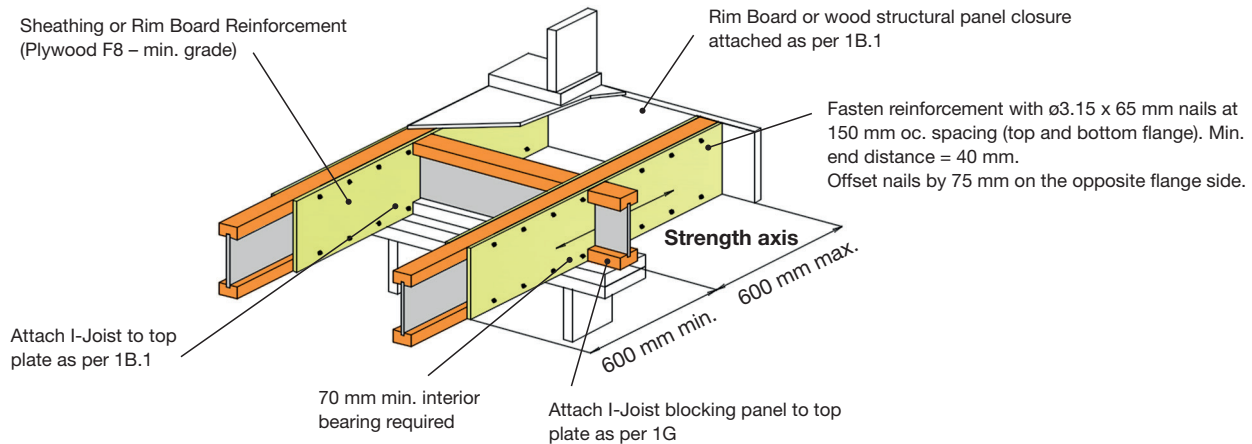

* Reinforcement shall match the full height of the joist.

Method 2 (alternate) – Double I-Joists

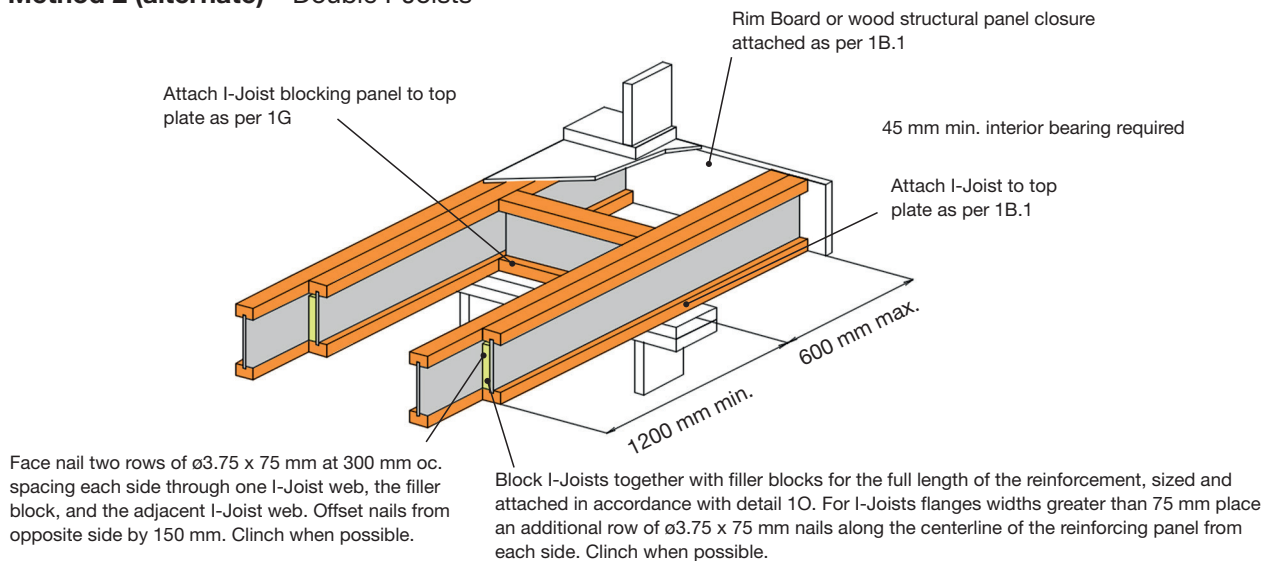

* Filler block does not function as a web stiffener. If web stiffeners are required, it is recommended to install continuous filler block and install web stiffener below filler block prior to attaching I-Joist reinforcement. Leave 6 mm gap between the top of filler block and bottom of top I-Joist flange. Web stiffeners must be tight between top of bottom flange and bottom of filler block.

Cantilevers for balconies (No wall load from above)

Figure 6

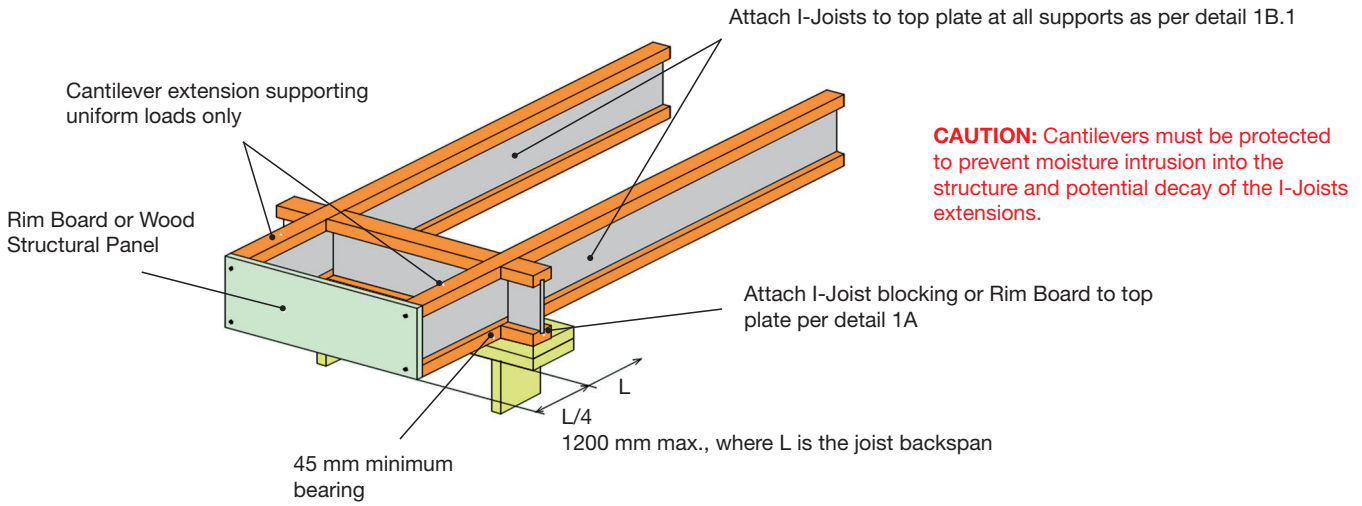
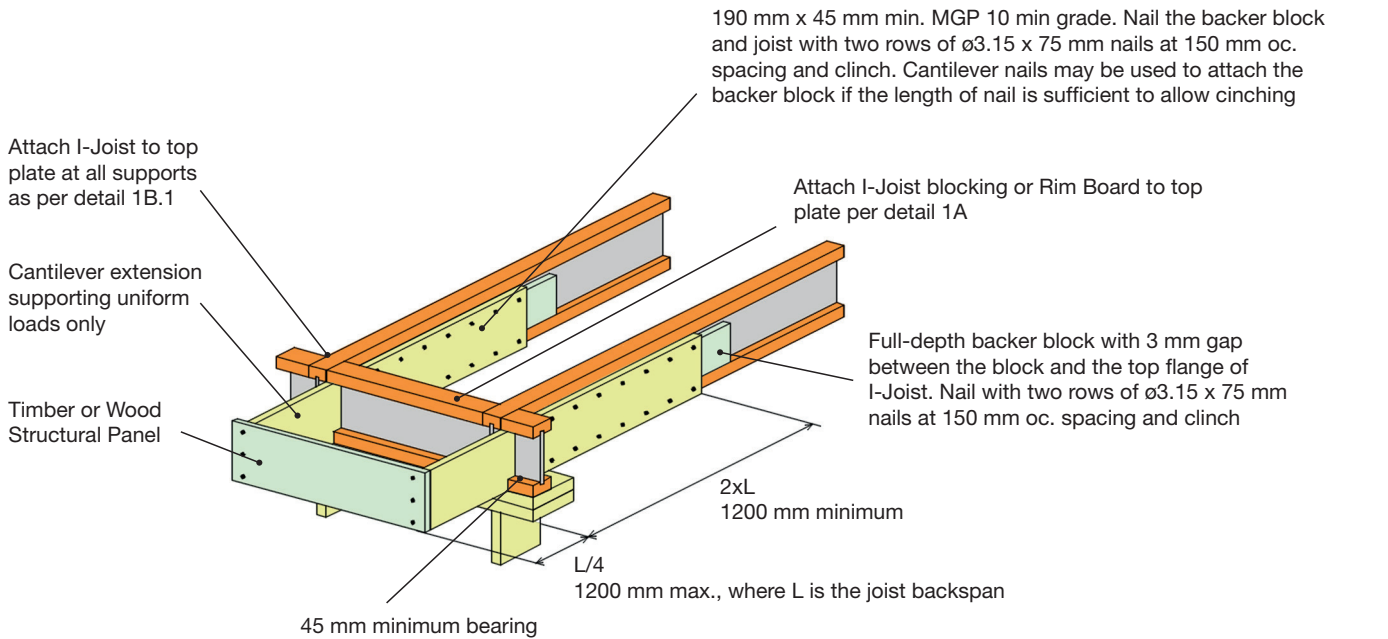

Figure 7



I-Joist cantilever reinforcement methods allowed (Continued)

Joist series	Joist depth (mm)	Roof truss span (m)	Roof loading					
			Roof dead load = 40 kg/m ²			Tiled roof dead load = 90 kg/m ²		
			Joist spacing (mm)			Joist spacing (mm)		
			300	450	600	300	450	600
RPFI® 20	240	8	0	0	0	0	0	x
		10	0	0	0	0	x	x
		12	0	0	0	x	x	x
		14	0	0	1	x	x	x
		16	0	0	x	x	x	x
	300	8	0	0	0	0	0	2
		10	0	0	0	0	2	2
		12	0	0	1	0	x	x
		14	0	0	1	0	x	x
		16	0	0	2	0	x	x
	360	8	0	0	0	0	1	2
		10	0	0	0	0	2	2
12		0	0	1	0	x	2	
14		0	0	2	0	x	2	
16		0	0	2	1	x	x	
RPFI® 400	240	8	0	0	0	0	0	x
		10	0	0	0	0	x	x
		12	0	0	0	0	x	x
		14	0	0	0	x	x	x
		16	0	0	0	x	x	x
	300	8	0	0	0	0	0	2
		10	0	0	0	0	0	2
		12	0	0	0	0	1	x
		14	0	0	0	0	2	x
		16	0	0	0	0	x	x
	360	8	0	0	0	0	0	2
		10	0	0	0	0	0	2
		12	0	0	0	0	1	2
		14	0	0	0	0	2	2
		16	0	0	0	0	x	2
	400	8	0	0	0	0	0	2
		10	0	0	0	0	0	2
		12	0	0	0	0	1	2
14		0	0	0	0	x	2	
16		0	0	1	0	x	2	
RPFI® 70	240	8	0	0	0	0	0	0
		10	0	0	0	0	0	x
		12	0	0	0	0	0	x
		14	0	0	0	0	x	x
		16	0	0	0	0	x	x
	300	8	0	0	0	0	0	0
		10	0	0	0	0	0	2
		12	0	0	0	0	0	2
		14	0	0	0	0	1	2
		16	0	0	0	0	2	x
	360	8	0	0	0	0	0	0
		10	0	0	0	0	0	2
		12	0	0	0	0	0	2
		14	0	0	0	0	1	2
		16	0	0	0	0	2	2
	400	8	0	0	0	0	0	1
		10	0	0	0	0	0	2
		12	0	0	0	0	0	2
14		0	0	0	0	1	2	
16		0	0	0	0	2	2	
RPFI® 90	300	8	0	0	0	0	0	0
		10	0	0	0	0	0	0
		12	0	0	0	0	0	0
		14	0	0	0	0	0	0
		16	0	0	0	0	0	1
	360	8	0	0	0	0	0	0
		10	0	0	0	0	0	0
		12	0	0	0	0	0	0
		14	0	0	0	0	0	0
		16	0	0	0	0	0	1
	400	8	0	0	0	0	0	0
		10	0	0	0	0	0	0
		12	0	0	0	0	0	0
		14	0	0	0	0	0	0
		16	0	0	0	0	0	1

Figure 5B

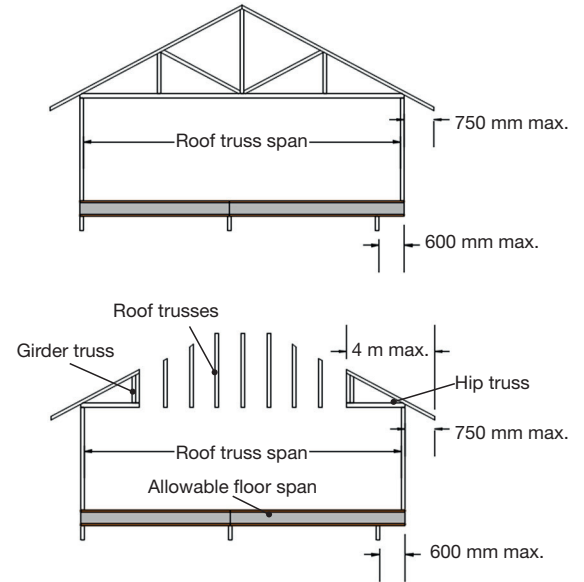

For hip roofs with the hip trusses parallel to the cantilevered floor joists, the I-Joist reinforcement requirements from the 8 m shall be permitted.

See cantilever reinforcement table on the left for I-Joists reinforcement requirements at cantilever.

Notes:

1. Table values are valid for the allowable RPFI® Joists design spans (single or continuous) for Category 1 or 2 applications.
2. The floor live load shall not exceed 1.5 kPa; For other load conditions, contact **Dindas Australia**.
3. Maximum cantilever length = 600 mm
4. The truss span is the out-to-out distance over the exterior bearing walls plus a max. 750 mm roof overhang on each side.
5. Table values assume a **bearing length adjacent to the cantilever of at least 70 mm** and a MGP10 bearing plate.
6. Exterior bearing wall weight = 1.2 kN/m.
7. Minimum 17 mm Plywood – F8 reinforcement.
8. Reinforcement shall match the joist depth.
9. Reinforcement length shall be min. 1220 mm from the end of the cantilever.
10. Table applies to joist with a max. spacing of 600 mm. Use 300 mm spacing requirements for spacings less than 300 mm.
11. Roof slope <= 35°
12. Max. cantilever total load deflection is 6 mm or Cant. Length/150, whichever is lower.
13. Max. cantilever live load deflection is 4.5 mm or Cant. Length/180, whichever is lower.

* Designs shown in red must be validated by **Dindas Australia's Engineering Team**.

Key

- 0 = no web stiffeners or reinforcement required
- ws = web stiffeners required at the interior bearing support
- 1 = web stiffeners + 1 side reinforcement required
- 2 = web stiffeners + 2 sides reinforcement
- x = try a deeper joist or closer spacing

Typical roof framing and construction details

Figure 8

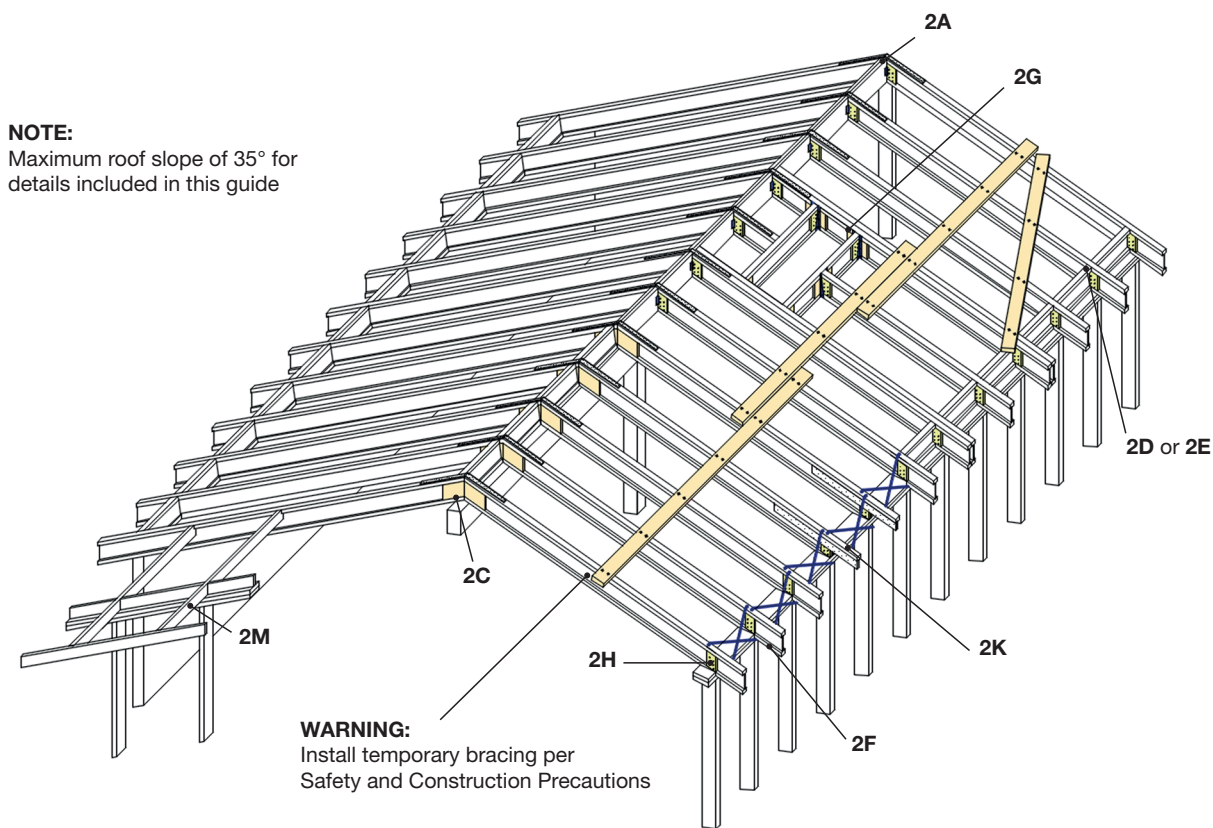

Notes:

1. Do not allow workers on Roof I-Joists until all hangers, Rim Joists, Rim Boards, RFPI® Blocking Panels, and temporary strut lines are installed as specified below.
2. Failure to install temporary bracing may result in sideways buckling or roll-over under light construction loads.
3. Before laying out roof system components, verify that I-Joist flange widths match hanger widths.
4. When battens are installed, never deliberately walk on the battens mid span between the rafters.
5. Install temporary bracing per Safety and Construction Precautions.
6. The end of the cantilevers must be temporarily secured by bracing on both the top and bottom flanges.
7. Remove the temporary bracing only as required to install the permanent sheathing.
8. Except for cutting to length, never cut, drill, or notch I-Joist flanges.
9. I-Joists are produced without camber so either flange can be the top or bottom flange; however, orienting the floor I-Joists so the pre-scored knockouts are on the bottom may ease installation of electrical wiring or residential sprinkler systems.
10. Install I-Joists so that top and bottom flanges are within 2 mm of true vertical alignment.
11. I-Joists must be anchored securely to supports before roof sheathing is attached, and supports for multiple-span joists must be level.
12. Minimum bearing lengths: 45 mm for end bearings and 90 mm for intermediate bearings.
13. When using hangers, seat I-Joists firmly in hanger bottoms to minimise settlement.
14. Leave a 2 mm gap between the I-Joist end and a header.
15. Concentrated loads greater than those that can normally be expected in residential construction should only be applied to the top surface of the top flange. Never suspend unusual or heavy loads from the I-Joist's bottom flange. Whenever possible, suspend all concentrated loads from the top of the I-Joist. Or, attach the load to blocking that has been securely fastened to the I-Joist web.
16. Never install I-Joists where they will be permanently exposed to weather or where they will remain in direct contact with concrete or masonry.
17. Restrain ends of roof joists to prevent rollover. Use rimboard, rim joists or I-Joist blocking panels.
18. For I-Joists installed over and beneath bearing walls, use full depth blocking panels, rimboard, or squash blocks to transfer gravity loads through the roof system to the wall or structure below.
19. Due to shrinkage, common framing timber set on edge cannot be used as blocking or rim boards. I-Joist blocking panels or other engineered wood products – such as rimboard – must be cut to fit between the I-Joists, and an I-Joist-compatible depth selected.
20. Provide permanent lateral support of the bottom flange of all I-Joists at interior supports of multiple-span joists. See table on page 4 for recommended sheathing attachment with nails.
21. Do not stack construction materials (roof cladding, gyprock etc.) in the middle of the RFPI® I-Joist rafters.

Roof framing details

Diagram 2A Ridge Beam Rafter Connection

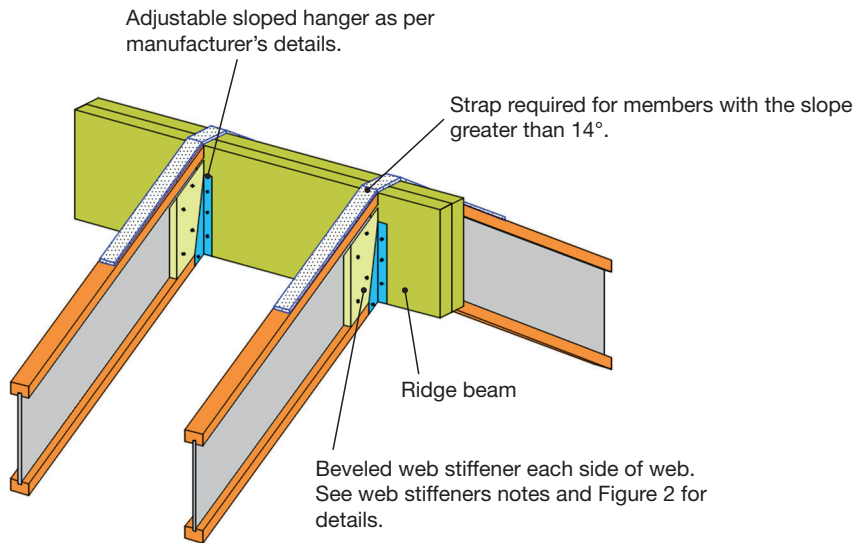

Diagram 2B Upper End, Rafters Bearing on Wall

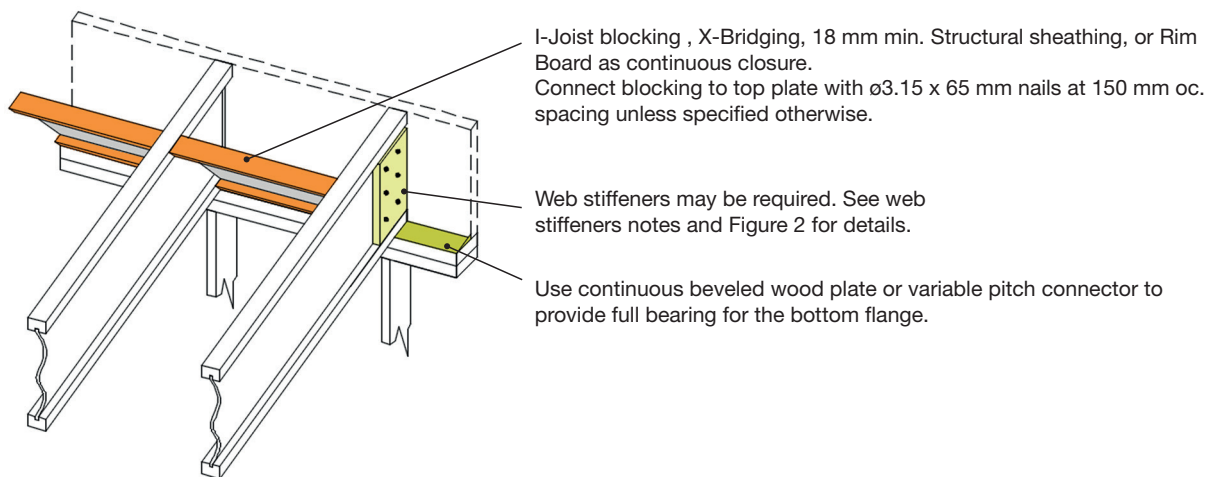
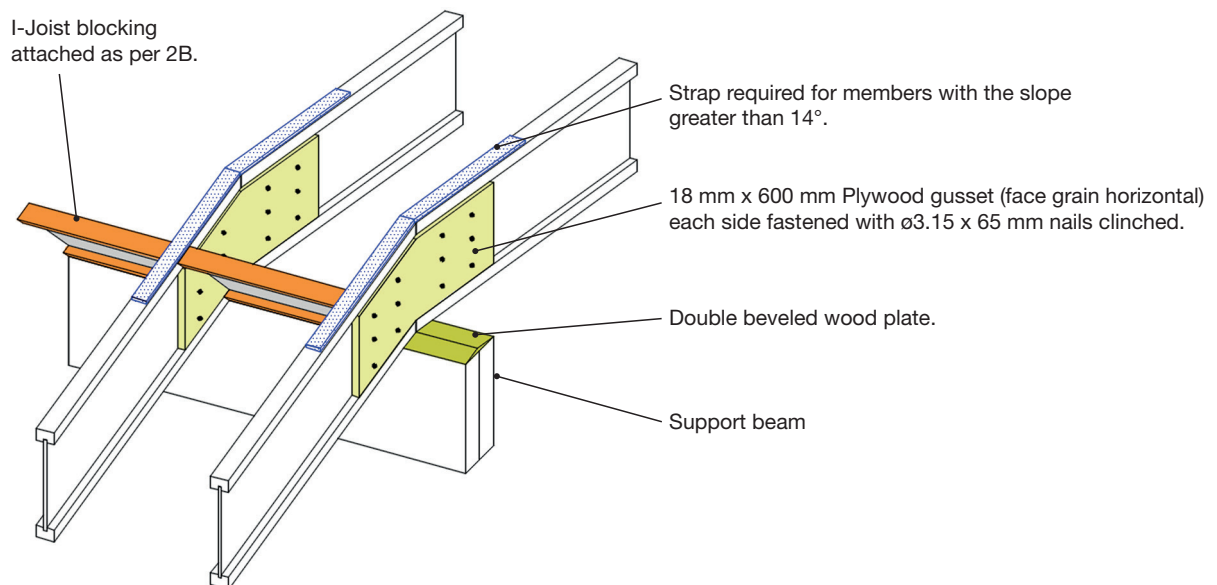
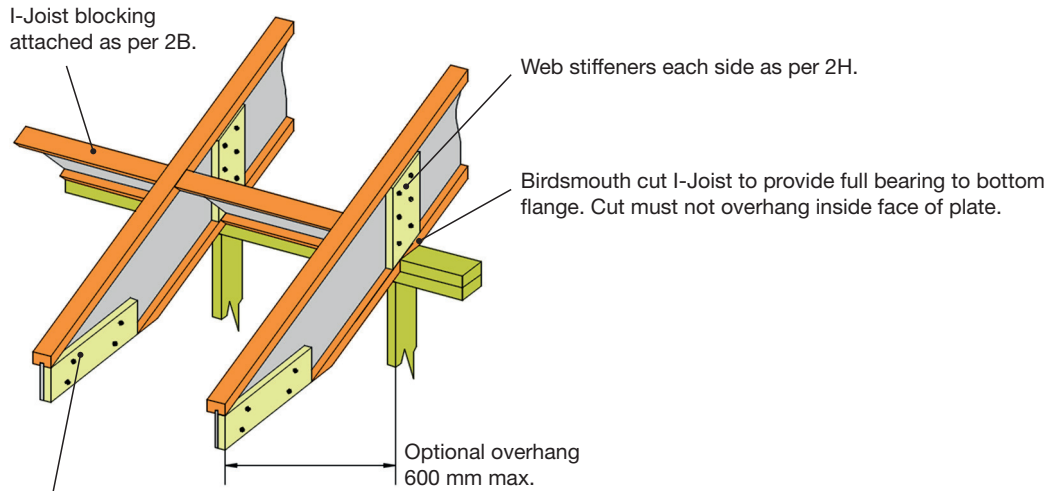

Diagram 2C Rafter Connection with Fitted Plywood Gusset



Roof framing details (Continued)

Diagram 2D Birdsmouth Cut with I-Joist Blocking



MGP10 90 mm x 45 mm blocking for fascia support.
Use two rows of $\phi 3.15 \times 65$ mm nails (clinched) at 100 mm oc. spacing.

Diagram 2E Rafters on Beveled Plate

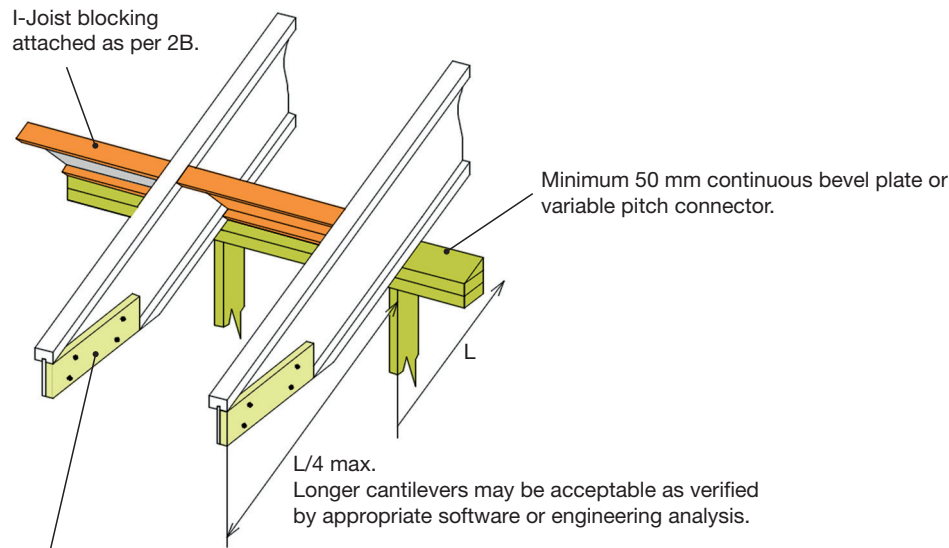

MGP10 90 mm x 45 mm blocking for fascia support.
Use two rows of $\phi 3.15 \times 65$ mm nails (clinched) at 100 mm oc. spacing.

Diagram 2F Birdsmouth Cut with X-Bridging

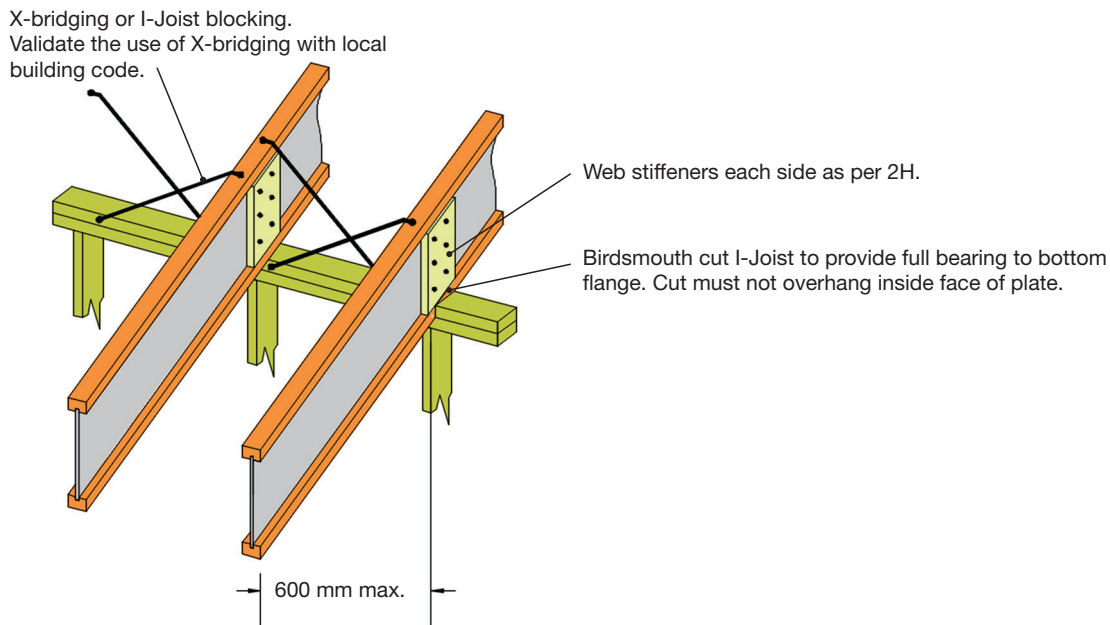

Diagram 2G Roof Opening Hanger Connections

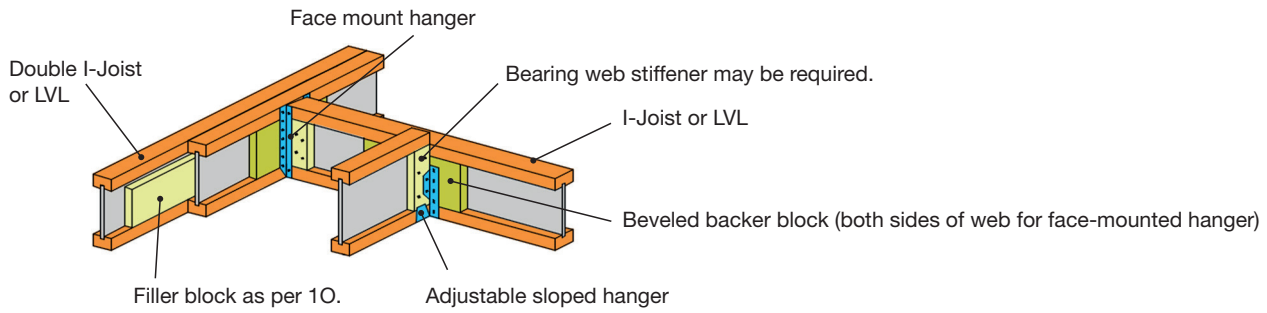

Diagram 2H Birdsmouth Cut Bearing Stiffener

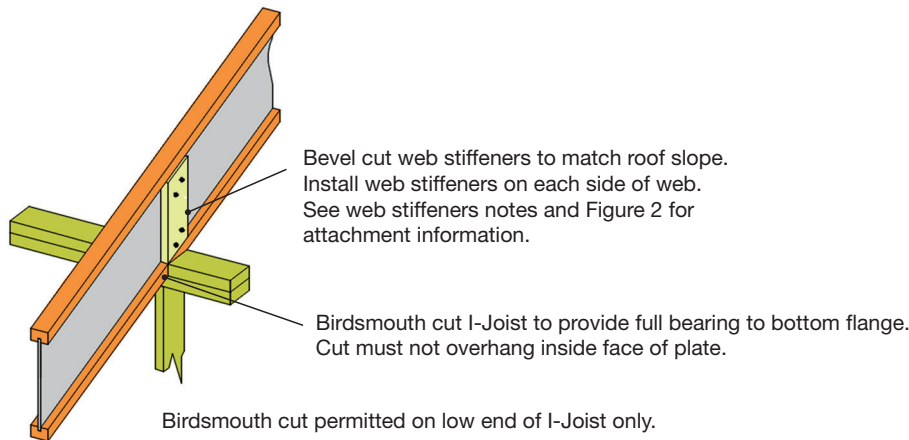

Diagram 2K Optional Overhang Extension

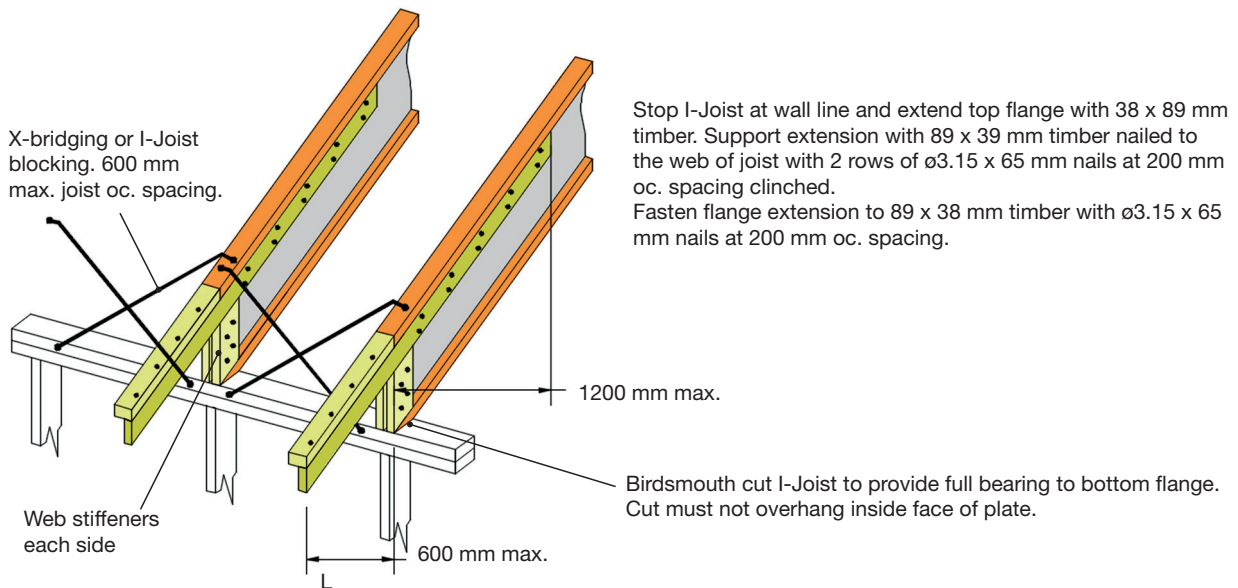
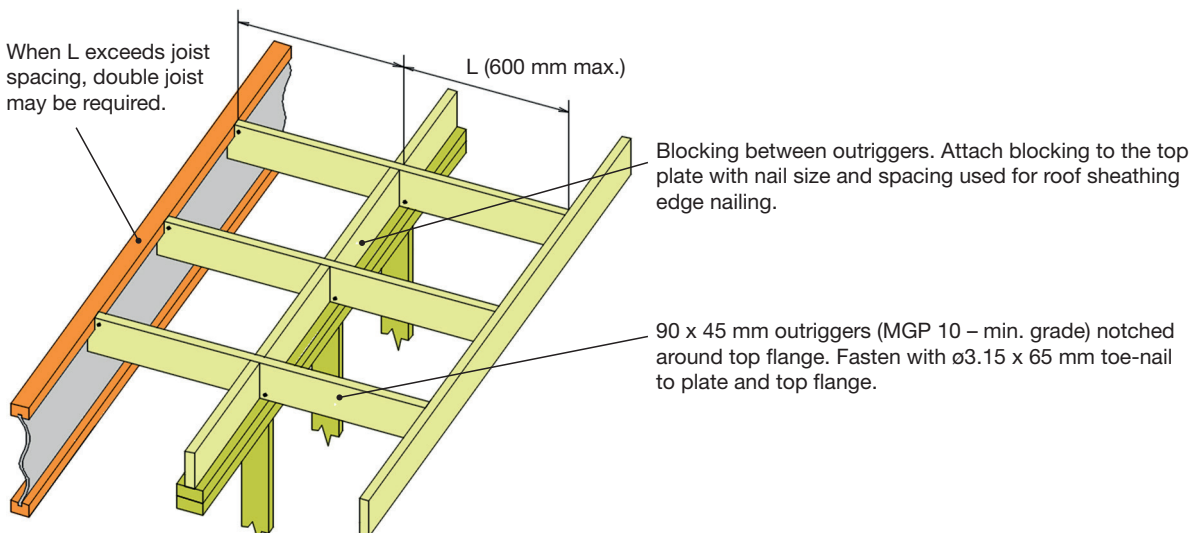
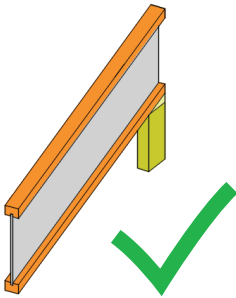

Diagram 2M Overhang Parallel to Rafter



Construction precautions

DO



Continuous wedge or approved connectors

DO NOT

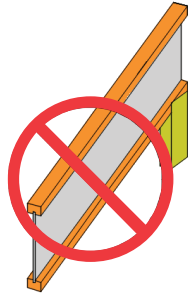

Do not birdsmouth cut bottom flange at high end support of rafter

DO

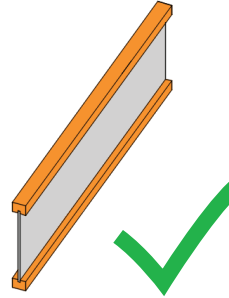

DO NOT

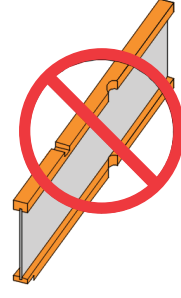

Do not cut or notch flanges (except birdsmouth cuts allowed as per roof details)

DO

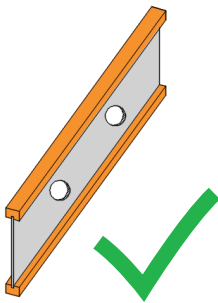

DO NOT

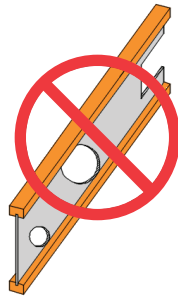

Do not violate hole charts rules

DO

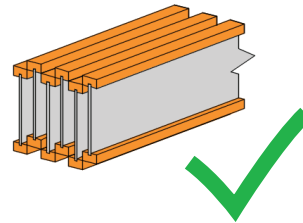

DO NOT

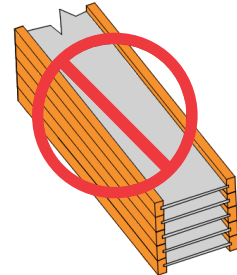

DO

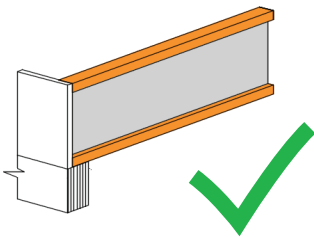

DO

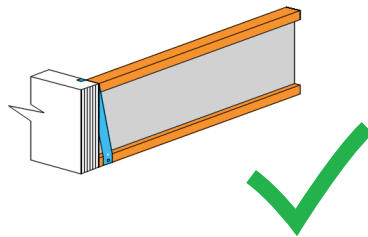

DO NOT

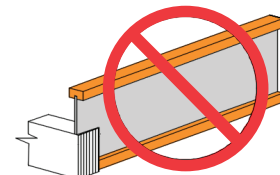

Do not hang I-Joist by top flange or web

Safety and construction precautions

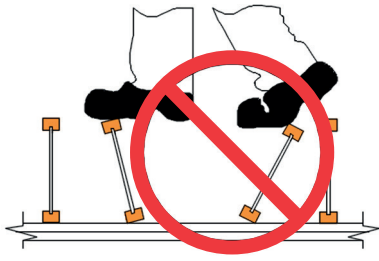

Do not allow workers to walk on I-Joists until they are fully installed and braced, as serious injuries can result.

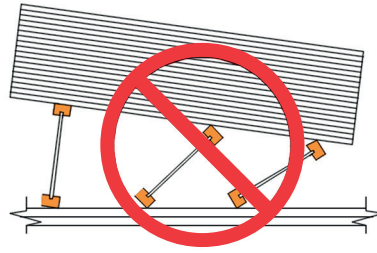

Never stack building materials over unbraced I-Joists. Stack only over braced beams or walls. See APA Technical Note number J735B "Temporary Construction Loads Over I-Joist Roofs and Floors" for additional information regarding proper stacking of building materials.

Warning:

I-Joists and LVL beams are not stable until completely installed, and will not carry any load until fully braced and sheathed.

1. Avoid accidents by following these important guidelines:
2. Brace and nail each I-Joist as it is installed, using hangers, blocking panels, rim board, and/or cross-bridging at joist ends.
3. When the building is completed, the floor sheathing will provide lateral support for the top flanges of the I-Joists. Until this sheathing is applied, temporary bracing, often called struts, or temporary sheathing must be applied to prevent I-Joist rollover or buckling.

- Temporary bracing or struts must be at least 2.5 m long and spaced no more than 2.5 m on center, and must be secured with a minimum of two $\phi 3.15 \times 65$ mm nails fastened to the top surface of each I-Joist. Nail bracing to a lateral restraint at the end of each bay. Lap ends of adjoining bracing over at least two I-Joists.
 - Or, sheathing (temporary or permanent) can be nailed to the top flange of the first 2.5 m of I-Joists at the end of the bay.
4. For cantilevered I-Joists, brace top and bottom flanges, and brace ends with closure panels, rim board, or cross-bridging.

5. Install and nail permanent sheathing to each I-Joist before placing loads on the floor system. Then, stack building materials over beams or walls only.
6. Never install a damaged I-Joist or beam.

Improper storage or installation, failure to follow applicable building codes, failure to follow span ratings for I-Joists, failure to use allowable hole sizes and locations, or failure to use web stiffeners when required can result in serious accidents. Follow these installation guidelines carefully.

Storage and handling guidelines

DO

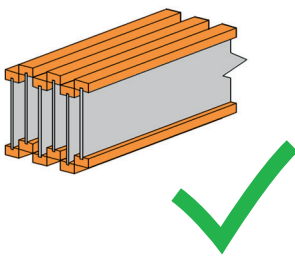

1. Do not drop I-Joists off the delivery truck. Best practice is use of a forklift or boom.
2. Store bundles upright on a smooth, level, well-drained supportive surface.
3. Do not store I-Joists in direct contact with the ground. Bundles should be a minimum of 150 mm off the ground and supported every 3 m or less.
4. Always stack and handle I-Joists in their upright position only.
5. Place 45 mm spacers (at a maximum of 3 m apart) between bundles stored on top of one another. Spacers above should be lined up with spacers below.

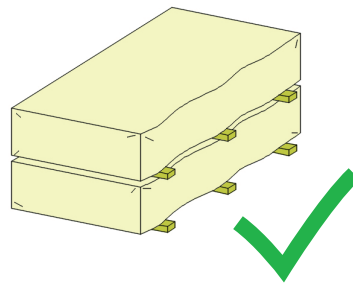

6. Bundles should remain wrapped, strapped, and protected from the weather until time of installation.
7. Do not lift I-Joists bundles by top flange.
8. Avoid excessive bowing or twisting of I-Joists during all phases of handling and installation (i.e. measuring, sawing or placement). Never load I-Joists in the flat-wise orientation.
9. Take care to avoid forklift damage. Reduce forklift speed to avoid "bouncing" the load.

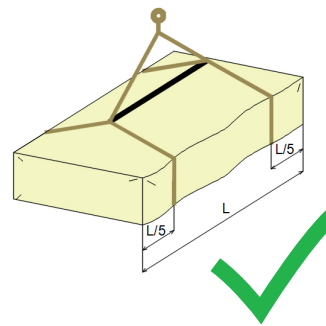

DO NOT

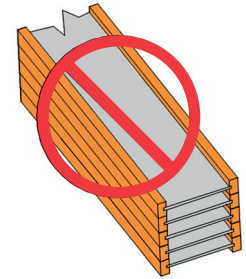

10. When handling I-Joists with a crane ("picking"), take a few simple precautions to prevent damage to the I-Joists and injury to your work crew:
 - Pick I-Joists in the bundles as shipped by the supplier.
 - Orient the bundles so that the webs of the I-Joists are vertical.
 - Pick the bundles at the 5th points, using a spreader bar if necessary.
11. Do not stack LVL/Timber/Glulam bundles on top of I-Joist bundles.
12. Never use a damaged I-Joist. All field repairs must be approved by Dindas.

Design and take-off service

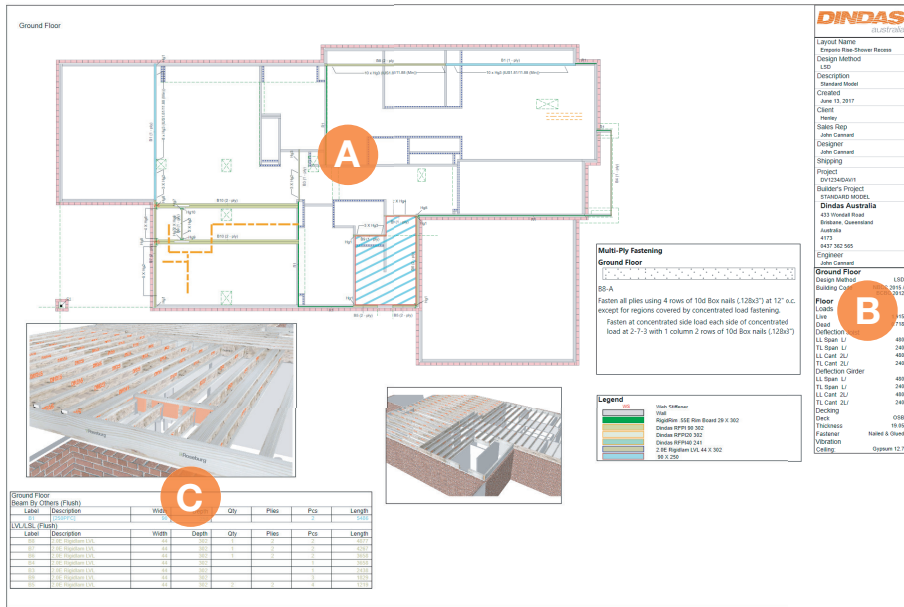

A. Cost-effective joist selection B. Take-off list C. Bracket selection *

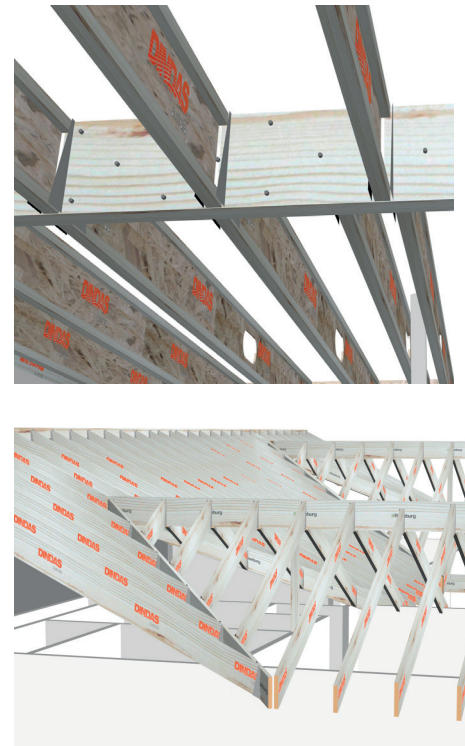

Product and performance warranty

Dindas warrants that the RFPI® I-Joists will be free from manufacturing errors and defects in workmanship and materials.

Furthermore, Dindas warrants that these products, when properly stored, installed and used in dry use service conditions, will meet or exceed the performance specified for the expected life of the structure.

For more information visit dindas.com.au

VICTORIA

58 Whiteside Road, Clayton
 Phone 03 8540 0500
 Fax 03 8540 0599
 Email vicestimating@dindas.com.au

NEW SOUTH WALES

138 Dunheved Circuit, St Marys
 Phone 02 9673 8000
 Fax 02 9673 8099
 Email nswestimating@dindas.com.au

QUEENSLAND

433 Wondall Road, Tingalpa
 Phone 07 3249 9888
 Fax 07 3249 9899
 Email qldestimating@dindas.com.au

